

How to get a European patent

Guide for applicants Part 1

December 2007
(11th edition)

Contents

Foreword	7
A. General	9
I. Introduction	9
II. Nature and purpose of the European Patent Convention	10
III. Relationship to other international conventions	10
IV. Choosing a route: national, European or international	11
Legal factors	11
Economic factors	12
V. Extending European patents to non-EPC states	13
B. Patentability	14
I. Invention	14
II. Novelty	15
Basic principles	15
Prior rights	15
III. Inventive step	16
C. Preparing and filing a European patent application	17
I. Formal requirements	17
Entitlement to file European patent applications	17
States for which European patent applications may be filed	17
Languages for European patent applications	18
Language arrangements to assist applicants from certain contracting states	18
Items making up a European patent application	18
Request for grant	19
Designation of inventor	19
Claiming priority	19
Filing by reference	20
Representation	21
II. Presenting your invention	22
Disclosing your invention	22
Unity of invention	23
Drafting the technical application documents	23
Description	24
Biotechnology applications	25
(a) <i>Nucleotide and amino acid sequences</i>	25
(b) <i>Depositing biological material to supplement the description</i>	25
Claims	26
Claims incurring fees	28
Drawings	28
Abstract	28
Prohibited matter	29
Unitary character of European patent applications and patents	29

III. Filing European patent applications	30
Where to file	30
How to file	30
Confirmation on paper.....	30
Date of receipt.....	30
Acknowledgement of receipt.....	31
Applications filed with national authorities and forwarded to the EPO	31
Fees	32
Fee amounts and payment methods.....	33
IV. Filing other documents	35
Where and how to file	35
Signature.....	35
Confirmation on paper.....	35
Date of receipt.....	35
Acknowledgement of receipt.....	36

D. The European patent grant procedure 37

I. General survey	37
II. Procedure up to publication of the application	38
Examination on filing.....	38
Formalities examination	38
European search report	39
III. Publication of the European patent application	40
IV. Examination procedure	41
Request for examination	41
Stages of the procedure.....	42
Amending applications before and during examination proceedings.....	44
National requirements governing translations of European patents	45
V. Opposition procedure	45
Opposition period	45
Grounds for opposition.....	46
Form and content of the notice of opposition	46
Examining the notice of opposition for admissibility.....	46
Substantive examination of the opposition.....	47
VI. Limitation and revocation procedure	48
VII. Appeals procedure	49
Filing an appeal.....	49
Interlocutory revision.....	49
Stages of the procedure before the boards of appeal.....	50
Petition for review.....	50
VIII. Divisional applications	51
IX. Renewal fees	52
X. General provisions governing periods	52
Missed time limits.....	53
Completion of an omitted act	53

Annex I	55
Charts showing the procedure for the grant of a European patent	55
Overview of procedure	55
Flowchart of the European patent grant procedure.....	56
Procedures for limitation, revocation and opposition	58
Annex II	59
Notice from the European Patent Office dated 14 July 2007 concerning the programme for accelerated prosecution of European patent applications – "PACE"	59
Search.....	59
Examination	60
Other ways of accelerating the European grant procedure.....	60
Annex III	61
Examples of European patent applications	61
Chemistry	62
Electricity/physics.....	75
Mechanics.....	87
Annex IV	104
Authorities with which European patent applications may be filed	104
I. European Patent Office	104
II. National authorities	104
Annex V	105
The requirements of the contracting states regarding translations of European patent specifications	105
I. Article 65 EPC	105
II. Requirements of the contracting states	105
Annex VI	106
Time limits	106
Charts showing time limits to be met by applicants	106
Annex VII	109
Fees	109
I. Fees provided for in the EPC.....	109
II. Form for the payment of fees and costs	109
III. Further information on fees.....	109

Annex VIII	110
Patent information services	110
File inspection and communication of information from files.....	110
European Patent Register and European Patent Bulletin.....	110
Patent documents.....	110
Official Journal, Guidelines and board of appeal decisions.....	111
Terms and conditions.....	111
Contact.....	111

Foreword

The "Guide for applicants" has been designed to provide companies, inventors and their representatives with an outline of the procedure involved in applying for a European patent.

This thoroughly revised and expanded new edition (December 2007) of the first part of the Guide is based on the revised EPC (EPC 2000), which entered into force on 13 December 2007. All references to articles or rules in this Guide therefore relate to the EPC as in force since that date. Please note, however, that in some cases certain provisions of the earlier European Patent Convention (EPC 1973) will continue to apply for applications which were pending at the time the revised EPC entered into force.

The second part of the Guide is devoted to the Euro-PCT route (How to get a European patent, Guide for applicants - Part 2, Euro-PCT, see point 8).

A. General

I. Introduction

- 1 This Guide outlines the provisions relevant to the filing of European patent applications, offering practical advice to smooth the way to a European patent. It cannot, however, go into the details or specific issues of the European patent grant procedure, and it does not constitute an official commentary on the European Patent Convention (EPC).

If you need more detailed information, you are advised to consult the "Guidelines for Examination in the European Patent Office", a comprehensive guide to every stage of the grant procedure and to EPO practice.

The charts in Annexes I and VI to the present Guide illustrate the course of the grant procedure and the time limits applicants have to observe.

- 2 In the right-hand margin you will find references to the provisions of the EPC, the Implementing Regulations and the Rules relating to Fees, and to passages from the Guidelines and the Official Journal (OJ) of the EPO. You are strongly advised to consult the works in question before taking any decisions in practice.

The authentic texts of the EPC and the Guidelines are given in two EPO publications, the **European Patent Convention** and the **Guidelines for Examination in the European Patent Office**. We also refer you to the **Ancillary Regulations to the European Patent Convention**, a collection of important texts relating to the European patent grant procedure. You should ensure that you use the latest edition of these or any of the other publications mentioned in this Guide.

A selection of important decisions of the EPO boards of appeal (see points 197-207) is published in the OJ and on the EPO website. We recommend that you consult the relevant decisions when questions regarding the interpretation of particular EPC provisions arise. The boards' decisions are also recorded on the ESPACE LEGAL CD-ROM. The **Case Law of the Boards of Appeal of the EPO** contains brief summaries of selected decisions and makes it easier to find the relevant ones.

The most important sources for European patent law and EPO practice, along with much other useful information, are accessible on the **Internet** via the **EPO website** (www.epo.org).

- 3 As in any other patent grant procedure, you need to be thoroughly familiar with patent matters if you are to steer your way successfully through the European route. **So if you lack the requisite experience, we advise you to consult a professional representative before the EPO (see points 58-66).**
- 4 The EPO brochure entitled **National law relating to the EPC** contains detailed information on the regulations and requirements governing European patent applications and patents in the contracting states. A valuable supplement to this Guide, it is

obtainable free of charge from the EPO and can also be downloaded from the **EPO website** (*www.epo.org*).

II. Nature and purpose of the European Patent Convention

- 5 The EPC has established a single European procedure for the grant of patents on the basis of a single application and created a uniform body of substantive patent law designed to provide easier, cheaper and stronger protection for inventions in the contracting states.

In each contracting state for which it is granted, a European patent gives its proprietor the same rights as would be conferred by a national patent granted in that state (see point 39 for a list of the contracting states). If its subject-matter is a process, protection is extended to products directly obtained by that process. Any infringement of a European patent is dealt with by national law (but see point 9).

Art. 64

A published European patent application provides provisional protection which is no less than that conferred by a contracting state for a published national application and which must at least include the right to reasonable compensation in the event of wrongful infringement.

Art. 67

The standard term of a European patent is twenty years as from the date of filing. Provided that the annual renewal fees are duly paid, in most of the EPC contracting states patents remain in force for the maximum term.

Art. 63

Article 63(2) sets out circumstances in which the term of a patent can be extended or a longer term granted. This option is intended primarily for medical or plant protection product patents, where the administrative approval procedure takes so long that the useful life of the patent is diminished.

- 6 European patents may also be effective in some countries that have not acceded to the EPC (extension states). At present these are Albania, Bosnia and Herzegovina, Croatia, Serbia and the former Yugoslav Republic of Macedonia (see point 26).

III. Relationship to other international conventions

- 7 The EPC constitutes a special agreement within the meaning of the Paris Convention for the Protection of Industrial Property.

This means in particular that the provisions of the Paris Convention on claiming priority and the national treatment principle also apply in the European procedure and to European applications.

Since nearly all the contracting states of the EPC are members of the WTO, the relevant provisions of the TRIPS Agreement (Agreement on trade-related aspects of intellectual property rights) are implemented in the revised EPC.

- 8 The EPC further constitutes a regional patent treaty within the meaning of Article 45(1) PCT, which means that European patents can be granted on the basis of an international application filed under the PCT. The Euro-PCT Guide (Part 2 of the present Guide, "Euro-PCT") deals

*Art. 150-153
R. 157-165
Guid. A-VII;
Guid. E-IX*

with this filing route. It can be obtained free of charge from the EPO Information Offices at all sites or downloaded from the **EPO website** (www.epo.org).

- 9 The EPC also forms the basis for the planned EC Regulation on the Community Patent, intended in particular to provide for the uniform effect of European patents granted by the EPO for the territory of the EC (Community patents) and to create a centralised Community patent court (see Proposal for a Council Regulation on the Community patent, COM(2000) 412 final, which can be found on the European Union website at <http://europa.eu.int>). However, the Regulation on the Community patent has not yet entered into force. The same applies to the European Patent Litigation Agreement (EPLA), which aims to establish a unitary litigation system for European patents. Further information about these initiatives is available on the EPO's website at www.epo.org.

IV. Choosing a route: national, European or international

- 10 The European procedure has not superseded the national grant procedures. So when seeking patent protection in one or more EPC contracting states you have a choice between following the national procedure in each state for which you want protection and taking the European route, which in a single procedure confers protection in all the contracting states that you designate.
- 11 If you decide you want a European patent, you have a further choice between the direct European route and the Euro-PCT route (see point 8 and Part 2 of the Guide). With the direct European route, the entire European patent grant procedure is governed by the EPC alone; with the Euro-PCT route, the first phase of the grant procedure (the international phase) is subject to the PCT, while the regional phase before the EPO as designated or elected Office is governed primarily by the EPC.
- 12 We will now summarise the chief legal and economic factors that are likely to influence your choice between the European and national procedures.

Legal factors

- 13 A European patent is granted after an examination designed to establish whether the European patent application and the invention to which it relates comply with the patentability requirements of the EPC.

These requirements are the basis not only for the granting of a European patent, but also for the assessment of its validity by national courts. In addition, under the EPC the extent of the protection conferred by the European patent is determined uniformly for all the contracting states.

Art. 69, 138

- 14 The examination procedure is conducted by the EPO departments of first instance (Receiving Section and examining divisions); if they decide against your application, you can file an appeal before the boards of appeal of the EPO. Once a European patent has been granted, there follows a nine-month period in which third parties are entitled to file a reasoned notice of opposition; and at the end of the resulting opposition proceedings, either the patent is maintained as

Art. 16, 18

granted or as amended or it is revoked. The decision taken in the opposition proceedings can also be appealed.

Once it has been granted, you can file a request for limitation or revocation of your own patent.

Art. 105a, 105b

- 15** European patents have a uniform wording and a uniform extent of protection for all designated contracting states (but see points 91 and 102) and offer a high presumption of validity.

Patent law in the contracting states has been extensively harmonised with the EPC in terms of patentability requirements. However, as grant procedures continue to be differently structured and are conducted in parallel by several offices, the national route generally leads to national rights with differing extents of protection.

Economic factors

- 16** Processing fees in the European patent grant procedure are staggered; so at each stage of the procedure you have a further chance to decide, in the light of the completed stages, whether your interest in obtaining patent protection is still great enough to justify paying the next fee.

Art. 2 RFees

In particular, the separation between search and substantive examination (see points 130-132) enables you to decide in the light of the European search report (see point 144) whether it is worth requesting substantive examination.

- 17** In certain circumstances you may be interested in having your application processed faster, at the search stage or the substantive examination stage or both.

If so, the EPO will make every effort to reduce the usual processing times as much as it can, under the programme for accelerated prosecution of European patent applications (for details see Annex II).

*Special edition
No. 3, OJ 2007, F. 1.*

- 18** Your application may be a **first filing** with the EPO.

In that case, you will as a rule be sent the search report within **six** months of the date of filing (see Annex II, point 2).

- 19** Like a first filing with a national office, a European first filing gives rise to the right of priority for a national, European or international second filing made in the priority year (see points 52-56)

- 20** The European search fee is refunded in full or in part if the European search report can be based on an earlier search report already prepared by the EPO on a national, European or international application whose priority is claimed. To take advantage of this you should attach a copy of the earlier search report when filing your European patent application (sections 40 and 41 of the Request for Grant).

*Art. 9 RFees
Guid. A-XI,
10.2.1, 10.4, 10.5
Special edition
No. 3, OJ 2007, M.2.*

- 21** Taking into account the fees levied for the European grant procedure, costs for representation by a single agent and the cost of conducting the proceedings in a single language, a European patent as a rule costs about as much as three or four national patents.

22 The European procedure is conducted in one of the three official languages of the EPO (English, French, German), specifically the one in which you file your application or a translation thereof. In addition, if you are from a contracting state whose language is not one of the EPO's official languages, you enjoy certain advantages as regards languages and fees if you use an official language of your contracting state (see points 44-46).

*Art. 14(2), (3)
R. 6(3)
Art. 14(1) RFees*

23 In the final phase of the European patent grant procedure, however, you are required to file a number of translations. You have to provide the EPO with translations of the claims in its other two official languages; and most contracting states require you to file a translation of the European patent specification in one of their official languages, if different from the language of the proceedings, in order for the European patent to take effect there (see point 177).

*Art. 97
R. 71
Art. 65*

24 The European patent grant procedure lasts about three to five years from when the application is filed. It breaks down into two main stages. The first comprises formalities examination, search report preparation and the drafting of an opinion on whether the application and the invention to which it relates seem to meet the requirements of the EPC. The second comprises substantive examination.

R. 55-66

25 In the first of these stages there is no need for your active involvement unless the Receiving Section finds formal deficiencies. However, in the second stage - substantive examination - your application is assigned to an examining division, which usually communicates with you or your representative before deciding whether to grant the patent or refuse the application (see points 131 and 155-176).

R. 71-72

Competent preparation of the patent application and of all procedural steps before the EPO is a crucial factor in ensuring that the examination procedure runs quickly and satisfactorily (see point 3).

V. Extending European patents to non-EPC states

26 The European Patent Organisation has signed co-operation and European patent extension agreements with a number of states that are not party to the EPC.

*OJ 1994, 75;
OJ 1996, 82 (AL);
OJ 1997, 538 (MK)
OJ 2004, 619 (BA)
OJ 2004, 563 (RS)
Guid. A-III, 12*

As an applicant for a European patent you thus have a simple and cost-effective way of obtaining patent protection in such countries. If you request an extension and pay the extension fee(s) in time, you can have European patent applications (direct and Euro-PCT filings) and patents extended to these countries, where they will then in principle have the same effect as national applications and patents and enjoy essentially the same protection as patents the EPO grants for EPC contracting states. As of 1 January 2008 you can request extension to Albania, Bosnia and Herzegovina, Serbia and the former Yugoslav Republic of Macedonia.

The extension system is largely the same as the EPC system operating in the contracting states. For example, the period for payment of the extension fee is the same as the period for payment of designation fees. However, the extension system is based not on direct application of the EPC but solely on national law modelled on the EPC. Hence it is subject to the national extension rules of the country concerned.

B. Patentability

- 27 European patents are granted for inventions that are new, involve an inventive step and are susceptible of industrial application. An invention can belong to any field of technology. *Art. 52(1)*

I. Invention

- 28 The EPC does not define the meaning of "invention", but it does provide a non-exhaustive list of subject-matter and activities that may not be regarded as inventions, i.e. that are expressly excluded from patentability. *Art. 52(2), (3)*
Art. 53
Guid. C-IV, 2.1-2.3

In this respect your attention is particularly drawn to the following four fields:

- 29 The first is **programs for computers**, which are not regarded as inventions if claimed as such. However, a computer program is not excluded from patentability under Article 52 if, when running on a computer, it causes a further technical effect going beyond the "normal" physical interaction between the program (software) and the computer (hardware). An example of a further technical effect is where the program serves to control a technical process or governs the operation of a technical device. The internal functioning of the computer itself under the influence of the program could also bring about such an effect. *Art. 52(2)(c), (3)*
Guid. C-IV, 2.3.6

If the computer program itself is not excluded, it is immaterial whether the program is claimed by itself, as a data medium storing the program, as a method or as part of a computer system.

Thus computer programs are not automatically excluded from patentability. More information about the patentability of computer-implemented inventions is available from the EPO website (www.epo.org).

- 30 The second field is **methods for treatment** of the human or animal body **by surgery or therapy**, and **diagnostic methods** practised on the human or animal body. The exclusion from patentability does not apply to products, substances and compositions for use in such methods, e.g. medicaments or surgical instruments. Substances and compositions are in fact singled out for special treatment in the EPC as regards the novelty requirement: even a known substance or composition may be patented for further medical or veterinary uses, provided that such use is novel and inventive. *Art. 53(c)*
Guid. C-IV, 4. 8
Art. 54(4)-(5)
Guid. C-IV, 4.8

This exception does not exclude the patentability of other methods of treatment of live human beings and animals; the treatment of body tissues after they have been removed from the human or animal body and diagnostic methods applied to such tissues are patentable as long as the tissues are not returned to the same body. *Guid. C-IV, 4.8.1*

- 31 The third field is **plant and animal varieties** and essentially biological processes for the production of plants or animals, which are expressly excluded from patentability. *Art. 53(b)*
R. 26, 27
Guid. C-IV, 4.6

In the case of plant varieties, a separate form of protection is available in most contracting states and under EU law.

A process for the production of plants or animals is essentially biological if it consists entirely of natural phenomena such as crossing or selection.

The exclusion does not apply to microbiological processes or the products of such processes. In general, biotechnological inventions are also patentable if they concern biological material that is isolated from its natural environment or produced by means of a technical process, even if it previously occurred in nature.

Guid. C-IV, 4.7

- 31a** The last field is inventions excluded from patentability because their commercial exploitation would be contrary to "**ordre public**" or **morality**. In particular, patents are not granted in respect of processes for cloning human beings, processes for modifying the germ line genetic identity of human beings, uses of human embryos for industrial or commercial purposes, or processes for modifying the genetic identity of animals that are likely to cause them suffering without any substantial medical benefit to man or animal, and also animals resulting from such processes.

*Art. 53(a)
R. 28
Guid. C-IV, 4.4*

II. Novelty

*Art. 54, 55
Guid. C-IV, 6-9*

Basic principles

- 32** An invention is considered to be new if it does not form part of the state of the art.

Art. 54(1)

The definition of the state of the art in the EPC reflects the principle of absolute novelty: the state of the art comprises everything made available to the public anywhere in the world by means of a written or oral description, by use, or in any other way, before the date of filing or priority. However, novelty is prejudiced only by something which is clearly disclosed to a skilled person in a **single** source of prior art, e.g. in a patent application published before the date of priority.

*Art. 54(2), 89
Guid. C-IV, 6, 9*

- 33** An earlier disclosure of the invention is non-prejudicial only if it occurred no earlier than **six months** before the filing of the European patent application **and** was due to an evident abuse in relation to the applicant or to display at an exhibition falling within the terms of the Paris Convention on international exhibitions¹. Apart from these two cases, the second of which is rare in practice, any disclosure of the invention before the date of filing may be cited against the applicant as forming part of the state of the art, even if the applicant himself was responsible for the disclosure.

*Art. 55
R. 25
Guid. A-IV, 3
Guid. C-IV, 10*

Prior rights

- 34** The state of the art is also held to comprise the content of European patent applications filed before the date of filing or priority but not published until on or after that date.

*Art. 54(3), 89
Guid. B-VI, 4
Guid. C-IV, 7*

A PCT application which is filed before the date of filing or priority but not published until on or after that date and for which the EPO acts as designated Office forms part of the state of the art for the purposes of Article 54(3) if the filing fee has been paid to the EPO and the PCT application is published in one of the EPO's official languages (English, French or German). If the PCT application was published in

*Art. 153 (5)
R. 165
Guid. C-IV, 6.2*

¹ Every year in the April issue of its Official Journal the EPO publishes a list of exhibitions falling within the terms of this Convention that have been registered by the International Exhibition Bureau.

Arabic, Chinese, Japanese, Russian or Spanish, a translation into one of the official languages of the EPO is required (see point 8).

Everything in the earlier application as filed is prejudicial to novelty.

The consequences that any earlier national patent applications or patents have for the patentability of the invention in the designated contracting states are assessed by the competent national courts after the European patent has been granted (but see point 103).

Art. 139(2)
Guid. C-III, 7.2

- 35** As a rule, a conflict between two European patent applications has only limited consequences, as the disclosed content of the earlier application is relevant only to the assessment of the later application's novelty, not its inventive step. Hence the later application's claims can mostly be drafted in such a way that the earlier application is not prejudicial to novelty.

Art. 56
Guid. C-IV, 7

III. Inventive step

- 36** An invention is held to involve an inventive step if it is not obvious to the skilled person in the light of the state of the art (which does not include prior rights, see points 34-35). In assessing inventive step as opposed to novelty (see point 32), **multiple** sources of prior art may be applied.

Art. 56

The inventive step requirement is intended to prevent exclusive rights forming barriers to normal and routine development.

- 37** The Office seeks to make a realistic and balanced assessment of the inventive step criterion. Inventive step is usually evaluated on the basis of the "problem-solution" approach, in other words whether the solution presented to the problem in the patent application is obvious or not to the person skilled in the art.

Guid. C-IV, 11

This always depends on the specific circumstances of the case. Depending on the situation, various factors are taken into account, such as the unexpected technical effect of a new combination of known elements, the choice of specific process parameters within a known range, the difficulty the skilled person has in combining known documents, secondary indicia such as the fact that the invention solves a long-standing technical problem which there have been many attempts to solve, or the overcoming of a technical prejudice.

If you need more detailed information, you are advised to refer to the Guidelines and to the decisions of the boards of appeal (see point 2).

C. Preparing and filing a European patent application

I. Formal requirements

Entitlement to file European patent applications

- 38** A European patent application may be filed by any natural or legal person, or any body equivalent to a legal person, irrespective of nationality and place of residence or business (but see point 58). *Art. 58, 59, 118*
Guid. A-II, 2

A European patent application may also be filed by joint applicants or by two or more applicants designating different contracting states; where there are different applicants for different contracting states, they are regarded as joint applicants for the purposes of proceedings before the EPO (see also point 64).

States for which European patent applications may be filed

- 39** When filing a European patent application all the contracting states for which the EPC has already entered into force on the date of filing are deemed to be designated. *Art. 79*

These states are: Austria, Belgium, Bulgaria, Cyprus, Croatia (as of 1 January), Czech Republic, Denmark, Estonia, Finland, France, Germany, Greece, Hungary, Iceland, Ireland, Italy, Latvia, Liechtenstein, Lithuania, Luxembourg, Malta, Monaco, Netherlands, Norway (as of 1 January 2008), Poland, Portugal, Romania, Slovakia, Slovenia, Spain, Sweden, Switzerland, Turkey and United Kingdom.

Switzerland and Liechtenstein may only be designated jointly.

OJ 1980, 407

- 40** In addition, European patent applications and patents may be extended to a number of states not party to the EPC, these at present being Albania, Bosnia and Herzegovina, Serbia and the former Yugoslav Republic of Macedonia (see point 26). **References in this Guide to the designation of contracting states also apply to the extension to non-contracting states, unless explicitly stated otherwise.**

- 41** Even though all the contracting states are deemed to be designated upon filing of the application you must subsequently confirm the designations by paying the appropriate designation fees. *Guid. A-III, 12*

If you pay **seven times the amount** of one designation fee, you are deemed to have paid the designation fees for all the contracting states, and you do not need to give any further information about contracting states. If you intend to pay fewer than seven designation fees, you may indicate the relevant contracting states in section 31.1 in the request for Grant form (EPO Form 1001) or when you make your payment.

Art. 2, No. 3, RFees

As to the extension states, all the extension states are deemed to be requested in the Request for Grant form, but you need to confirm the request for extension by paying the extension fee for each state to which you wish to extend protection.

Languages for European patent applications

- 42 The official languages of the EPO are English, French and German. *Art. 14(1)*
- 43 If you file your European patent application in any other language, you need to file a translation into one of the official languages of the EPO within two months of filing the application. If the translation is not filed in time, you will be invited to file the translation within two months of the notification of the invitation. If the translation is not filed within the time limit set in the invitation, the application is deemed to be withdrawn. *Art. 14(1), (2)*
R. 6(1), 58

The language in which you file the application (or its translation, if not filed in English, French or German) is made the language of the proceedings, and any amendments made to the application or the European patent must be drawn up in that language. Otherwise, in written proceedings, any party may use any of the EPO's official languages.

Art. 14(3)
R. 3
Guid. A-VIII, 1.1-1.2

At any time during the proceedings before the EPO, the translation may be brought into conformity with the text of the application as filed.

Art. 14(2)

With regard to divisional applications see point 211.

Language arrangements to assist applicants from certain contracting states

- 44 If you (or one of your co-applicants) have your residence or principal place of business in a contracting state that has a language other than English, French or German as an official language, or if you (or one of your co-applicants) are a national of that state but are resident abroad, and you file a European patent application and request examination in one of the state's official languages, you will be entitled to a 20% reduction in the filing and examination fees (see also point 45). *Art. 14(4)*
R. 6(3)
Art. 14(1) RFees
Guid. A-VIII, 1.1
Guid. A-XI, 9.2
- 45 If point 44 applies to you, at any time in the procedure after filing your application you may file any documents subject to a time limit in an official language of your state; but within **one month** of filing any such document you must submit a translation into the language of the proceedings. *Art. 14(4),*
R. 6(2),(3)
Guid. A-VIII, 2
Art. 14(1) RFees
- 46 However, if you use the official language of your state for filing an opposition, appeal or petition for review, you can file the translation into one of the official languages of the EPO **within** the opposition, appeal or petition for review period respectively, if that period expires after the one-month period mentioned in point 45. If you do not file the translation in due time, the document is deemed not to have been filed.

The fee reduction mentioned in point 44 also applies to the fees for opposition, appeal, petition for review, limitation and revocation.

Items making up a European patent application

- 47 A European patent application consists of a **request** for the grant of a European patent, a **description** of the invention, one or more **claims**, any **drawings** referred to in the description or claims, and an **abstract**. *Art. 78(1)*
Guid. A-II, 4.1.3.1

Request for grant

- 48** The request **must** be filed on a **form prescribed by the EPO** (EPO Form 1001) which, together with explanatory notes, is obtainable free of charge from the EPO and from national industrial property offices. The form can also be downloaded from the EPO website or generated using the Online Filing software, also obtainable free of charge from the EPO (www.epo.org).

*R. 41
Guid. A-III, 4
Special edition
No. 7, OJ 2007*

You are strongly advised to read the notes carefully before completing the request form. By completing the form you meet all the mandatory requirements governing the information that the request for grant must contain. The request must be **duly signed**. It may be signed by your representative if you have appointed one. Where it is signed on behalf of a legal person, the position of the signatory within the legal entity must also be indicated.

*R. 41(2)(i)
R. 2(2)
Guid. A-III, 4.2.2*

One copy of the request itself must be filed; the receipt for documents (page 8 of the Request for Grant form) must be filed in triplicate, or in quadruplicate if filed with a national authority.

Designation of inventor

- 49** In your European patent application you must designate the inventor.

Art. 81

If you yourself are not the inventor or are not the sole inventor, you must file the designation of the inventor in a separate document, which must indicate the origin of your right to the European patent.

*R. 19
Guid. A-III, 5*

You can obtain forms for designating the inventor free of charge from the EPO and the national industrial property offices or you can download them from the EPO website (www.epo.org).

- 50** The person designated as the inventor will be mentioned in the published European patent application, in the European patent specification, in the Register of European Patents and in the European Patent Bulletin, unless he waives this right in due time in advance of publication.

*Art. 127, 129(a)
R. 20(1), 143(1)(g)
Guid. A-III, 5.2*

- 51** If you do not designate the inventor when you file the European patent application, you will be invited to correct this deficiency within **sixteen months** after the date of filing or the earliest priority date, and in any event no later than five weeks prior to the intended date of publication of the application. If you fail to submit the designation of inventor within the specified period, your application will be refused (see point 140).

*Art. 81, R. 60
Guid. A-III, 5.5*

Claiming priority

- 52** If you or your predecessor in title have duly filed an application for a patent, a utility model or a utility certificate in or for any state party to the Paris Convention for the Protection of Industrial Property or any member of the World Trade Organization you may claim priority when filing a European patent application in respect of the same invention. You must file the European patent application no later than **twelve months** after filing the first application (see points 226-228).

*Art. 87
Guid. A-III, 6
Guid. C-V, 1.3*

If the earlier application was filed in or for an EPC contracting state, you may also designate that state in the European application. The

earlier application whose priority you claim may also be a European or international (PCT) application (see point 19).

- 53** You may claim multiple priorities in respect of one European patent application, even if they originate from different countries. You may also claim multiple priorities for any one claim. If you claim multiple priorities, time limits which run from the date of priority are computed from the earliest priority date. *Art. 88(2), (3)*
Guid. C-V, 1.5
Guid. A-III, 6.3
- 54** To claim the priority of an earlier application you must indicate the date, country and file number of the earlier application. *Art. 88(1)*
R. 52, 53
Guid. A-III, 6.5, 6.7
Guid. C-V, 3
OJ 2007, 474
- You must also file the priority document, i.e. a copy of the earlier application certified by the authority with which it was filed, together with authentication of its filing date from that authority. The EPO adds a copy of the earlier application whose priority you claim to the file of the European patent application free of charge if the earlier application is either a European patent application, an international patent application filed with the EPO as receiving Office, a Japanese or Korean patent or utility model application, an international application filed with the Japan Patent Office as receiving Office or a United States provisional or non-provisional patent application.
- 55** You should preferably submit the declaration indicating the date, country and file number of the earlier application **when you file your European patent application**. *R. 41(2)(g)*
R. 52, 53
Guid. A-III, 6.5, 6.7
Guid. C-V, 3.2
- You must supply the priority document and the complete declaration of priority no later than **sixteen months** after the earliest priority date. *R. 52(2)*
R. 52(3)
- If you do not indicate the file number or file the copy of the earlier application within the above time limit, you will be invited to remedy the deficiency; if you fail to do so, you will lose your right to priority (but see point 141). *R. 59*
Guid. A-III, 6.9, 6.10
- 56** Among the effects of a valid claim to priority is that the date of priority determines the prior art that can be cited against the European patent application. *Art. 54(2), (3)*
Art. 60(2), 89
- As a rule, the EPO examines only the formal conditions for claiming priority. The examining division (see points 159 et seq.) normally checks whether a right to priority exists if it finds prior art (see point 32) from between the priority date and the date of filing of the European patent application or if it finds a prior right under Article 54(3) (see point 34). The claimed subject-matter for which priority is claimed must be derivable directly and unambiguously from the full disclosure of the invention in the priority document. *R. 53(3)*
Guid. A-III, 6.7
Guid. C-V
- You may be invited to file a translation of the earlier application into one of the EPO's official languages. If you receive such an invitation you must file the translation within the period set by the EPO. Alternatively, a declaration that the European patent application is a complete translation of the earlier application may be submitted in certain cases.
- Filing by reference** *R. 40(2),(3), 57(c)*
Guid. A-II, 4.1
- 57** When filing your patent application by reference to an earlier application, you should indicate in the Request for Grant form (section 26.1) the filing date, application number and the state in *Art. 14(2)*

which the earlier application was filed. The reference must indicate that it replaces the description and any drawings. You will then have to file a certified copy of the previously filed application within two months of filing the application. If the reference application is not in English, French or German, you must file a translation thereof within the same time limit. If you do not file the certified copy within the said time limit or within a time limit set in a subsequent invitation, the application will not be dealt with as a European patent application. If you do not file a translation of the earlier application within the said time limit or within a time limit set in an invitation, the application will be deemed to be withdrawn.

Claims can also be filed by reference to those in the previous application.

Representation

- 58** If you have your residence or principal place of business in a contracting state, you may act on your own behalf in proceedings before the EPO (but see point 3). *Art. 133(1)*
Guid. A-IX, 1
- If you have neither a residence nor your principal place of business in a contracting state, you must appoint a representative and act through him in all proceedings before the EPO other than in filing your European patent application and paying the fees. *Art. 133(2)*
- 59** Representation before the EPO may be undertaken only by professional representatives who are on a list maintained by the EPO, or by legal practitioners entitled to act before the EPO. You will find a searchable online database of professional representatives on the EPO website (*www.epo.org*). You can also order the directory of professional representatives from the EPO (Vienna) for an administrative fee. *Art. 134(1), (7)*
Guid. A-IX, 1.4
- 60** Representatives may be authorised either by individual authorisation or by general authorisation. The relevant forms, to which amendments are permitted, are available free of charge from the EPO and the national industrial property offices. They can also be downloaded from the EPO website (*www.epo.org*). *R. 152(1), (2)*
Guid. A-IX, 1.5
- As a rule, professional representatives who identify themselves as such no longer need to file individual authorisations. *OJ 1991, 489*
- General authorisations are registered at the EPO. These are a practical option for all concerned. *OJ 1985, 42*
OJ 1986, 327
- 61** If an authorisation is not filed within the period specified by the EPO, any actions taken by the representative other than the filing of the European patent application and the payment of fees are deemed not to have been taken. *R. 152(6)*
Guid. A-IX, 1.7
- 62** If several representatives are appointed, they may act either jointly or singly before the EPO, regardless of any provisions to the contrary in the notification of their appointment or in the authorisation. With multiple representatives it is also advisable to give the particulars of only one of them in the Request for Grant, appending "et al." to his name. *R. 152(10)*

- 63** If you have your residence or principal place of business in a contracting state, you may also be represented by your employees, who need not be professional representatives. *Art. 133(3)*
Guid. A-IX, 1.2

An employee who is representing his employer and who is not a professional representative must have an individual or general authorisation complying with the regulations referred to in point 60.

- 64** If an application is filed by more than one person, the Request for Grant should designate one of them or a professional representative as the common representative. Otherwise, the applicant named first in the Request for Grant is deemed to be the common representative. However, if one of the applicants is obliged to appoint a professional representative, the latter is deemed to be the common representative unless the applicant named first in the Request for Grant has appointed a professional representative. *Art. 133(4)*
R. 41(3)
R. 151(1)
Guid. A-IX, 1.3

- 65** The particulars of the representative's name and business address given in the Request for Grant are recorded in the Register of European Patents, published in the European Patent Bulletin and printed in the published European patent application and patent. *R. 143(1)(h)*
Art. 129(a)
R. 68

- 66** Notifications sent by the EPO (communications, notices, decisions and summonses) are addressed: *Art. 119*
R. 125–130
Guid. E-I, 2.4

(a) to the representative recorded in the Register of European Patents; or

(b) to you as applicant if you do not appoint a representative, and also if an employee is acting on your behalf.

If your business operates from different locations (i.e. comprises structural sub-divisions with no separate legal personality) and you wish notifications in proceedings before the EPO to be addressed to the department dealing with the application and to have a different address, e.g. your company's head office, used for publications and the Register of European Patents, you must indicate this separately in the Request for Grant (see point 48), section 9, "Address for correspondence".

II. Presenting your invention

Disclosing your invention

- 67** The European patent application must disclose the invention in a manner sufficiently clear and complete for it to be carried out by a person skilled in the art. *Art. 83, 84, 69(1)*

The description and any accompanying drawings form the basis for the claims, which determine the extent of the protection conferred by the European patent. The description and the drawings are also used to interpret the claims. *Guid. C-II, 4.1*
Guid. C-III, 6.1

- 68** Once a European patent application has been filed, no amendments extending beyond its content as filed may be made to the description, the claims or the drawings. Hence you are not allowed to add examples or features to the application documents at a later date to remedy deficiencies in the disclosure. Nor are you allowed to extend the subject-matter of the claims, e.g. by omitting certain features, unless *Art. 123(2)*
Guid. C-VI, 5.3
Guid. C-II, 4.3, 4.10

there is clear support for such extension in the application as filed. You must therefore make sure that the claims as filed clearly and accurately identify the invention that you want to protect (see also point 175).

Unity of invention

- 69** European patent applications must relate to a single invention only, or to a group of inventions so linked as to form a single general inventive concept. In the latter case, multiple independent claims in the same category are allowed as long as they comply with Rule 43(2); but the more usual scenario is multiple independent claims in different categories (see point 85).
- Art. 82
R. 43(2), 44
Guid. C-III, 7
OJ 2002, 112*

Drafting the technical application documents

- 70** The requirements relating to the content of the description, claims, drawings and abstract are set out in Articles 83, 84 and 85 and Rules 42, 43, 47 and 48.
- Art. 83-85
R. 42-50
Guid. A-IX, 2
Guid. A-X*

The formal requirements for these documents are defined in Rules 46, 47 and 49; those for documents filed subsequently are in Rule 50.

- 71** The following are the chief provisions governing the form of application documents and documents filed subsequently:
- R. 49
R. 50*

- (a) The documents making up the European patent application (description, claims, drawings and abstract) must be filed in a single copy. The same applies to documents replacing these original documents.
- (b) The documents must be on strong, pliable, white A4 paper (portrait format).
- (c) Each document making up the application (request, description, claims, drawings and abstract) must begin on a new sheet.
- (d) All the sheets must be numbered in consecutive Arabic numerals, which must be positioned top centre but not in the top margin.
- (e) The following minimum margins (type area) must be left blank:
top: 2 cm
left: 2.5 cm
right: 2 cm
bottom: 2 cm
- (f) The lines of each sheet of the description and the claims should be numbered in sets of five, the numbers appearing on the left side, to the right of the margin.
- (g) The line spacing must be 1.5.
- (h) There must be no handwritten additions to the text.

R. 49(12)

The special requirements for drawings are dealt with in the Guidelines, Part A, Chapter X.

72 Annex III gives three examples of how to draft a European patent application.

Description

73 In the description you must:

R. 42, Guid. C-II, 4

(a) Specify the technical field to which the invention relates. You may do this for example by reproducing the first ("prior art") portion of the independent claims in full or in substance or by simply referring to it.

R. 42(1)(a)

(b) Indicate the background art of which you are aware, to the extent that it is useful for understanding the invention, preferably citing source documents reflecting such art. This applies in particular to the background art corresponding to the prior art portion of the independent claims. Source document citations must be sufficiently complete to be verifiable: patent specifications by country and number; books by author, title, publisher, edition, place and year of publication and page numbers; periodicals by title, year, issue and page numbers.

*R. 42(1)(b)
Guid. C-II, 4.3-4.4*

(c) Disclose the invention as claimed.

*R. 42(1)(c)
Guid. C-II, 4.5-4.6*

The disclosure must indicate the technical problem that the invention is designed to solve (even if it does not state it expressly) and describe the solution.

To elucidate the nature of the solution according to the independent claims you can repeat or refer to the characterising portion of the independent claims (see example) or reproduce the substance of the features of the solution according to the relevant claims.

At this point in the description you need only give details of embodiments of the invention according to the dependent claims if you do not do so when describing ways of performing the claimed invention or describing what the drawings show.

You should state any advantageous effects your invention has compared with the prior art, but without making disparaging remarks about any specific previous product or process.

R. 48(1)(b)

(d) Briefly describe what is illustrated in any drawings, making sure you give their numbers.

*R. 42(1)(d)
R. 46(2)(i)
Guid. C-II, 4.7*

(e) Describe in detail at least one way of carrying out the claimed invention, typically using examples and referring to any drawings and the reference signs used in them.

*R. 42(1)(e)
Guid. C-II, 4.8-4.11*

(f) Indicate how the invention is susceptible of industrial application within the meaning of Article 57.

*R. 42(1)(f)
Guid. C-II, 4.12*

74 In exceptional cases you may arrange the description in a different manner and order if this affords a better understanding or a more economic presentation.

*R. 42(2)
Guid. C-II, 4.13*

- 75** Although the description must be clear and straightforward and avoid unnecessary technical jargon, the use of recognised terms of art is acceptable and often desirable. Little known or specially formulated technical terms may be allowed provided that they are adequately defined and that there are no generally recognised equivalents.

R. 49(11)
Guid. C-II, 4.14-4.19

You may use proper names or similar words to refer to a product only if they uniquely identify it. Even then, however, the product must be sufficiently identified, without reliance upon such terms, to enable the invention to be carried out by the skilled person. If such proper names or similar words are registered trade marks, that fact should be mentioned.

Biotechnology applications

(a) Nucleotide and amino acid sequences

- 75a** If your European patent application discloses nucleotide or amino acid sequences (unbranched sequences of four or more amino acids or unbranched sequences of ten or more nucleotides), the description must contain a sequence listing complying with WIPO Standard ST.25 and presented as a separate part of the description. The sequence listing must be filed both on paper and on an electronic medium. You are advised to use the EPO's free "PatentIn" software, which simplifies standardised sequence presentation.

R. 30, 57
Guid. A-IV, 5
Special edition
No. 3, OJ 2007, C.

If you file your application online in electronic form, you must send the sequence listing as an attachment to the online filing.

You must also fill in section 38 of the Request for Grant form (see annexes) to indicate that the application contains a sequence listing.

- 75b** The standardised presentation of such nucleotide and amino acid sequences is mandatory. If you do not comply with the requirements and do not, where applicable, pay the late furnishing fee even following an invitation to do so, your European patent application will be refused (but see point 225).

R. 30

(b) Depositing biological material to supplement the description

- 76** If your invention involves the use of or concerns biological material that is not available to the public and cannot be described in your European patent application in such a way that it can be carried out by a skilled person, you must deposit a sample of this biological material with a recognised depositary institution no later than at the date of filing.

Art. 53(b), 83
R. 31-34
Guid. A-IV, 4
Guid. C-II, 6
OJ 1986, 269,
amended by
OJ 1991, 461
OJ 1996, 390, 596

The recognised depositary institutions are the international depositary authorities under the Budapest Treaty on the International Recognition of the Deposit of Microorganisms for the Purposes of Patent Procedure and a number of other institutions designated by the President of the EPO. A full list of recognised depositary institutions is published once a year in the April issue of the EPO's Official Journal; the Official Journal also publishes changes to the list as they occur, and any other relevant information.

R. 33(6)
OJ (April issue)

- 77** The application as filed must also give any relevant information that is available to you on the characteristics of the biological material.

R. 31(1)(b)
Guid. C-II, 6.3

If the biological material has been deposited by someone else, you must state the depositor's name and address in your application and submit documents satisfying the EPO that the depositor has authorised you to refer to the deposited biological material in your application and has given his unreserved and irrevocable consent to the deposited material being made available to the public in accordance with Rule 33.

R. 31(1)(d)

- 78** Lastly you must state your chosen depositary institution and the accession number of the deposited biological material, as a rule within sixteen months after the date of filing or, if you have claimed priority, after the earliest priority date. If any of these requirements is not satisfied, the biological material in question cannot be considered as having been disclosed pursuant to Article 83 by way of reference to the deposit. Please refer to the Guidelines for Examination (C-II, 6.3) for further details.

R. 31(1)(c), (2)

- 79** You should also ensure that you complete sections 34 to 37 of the Request for Grant ("Biological material"). These are designed to alert the EPO that the application refers to biological material deposited under Rule 31 and to enable it to draw your attention to any deficiencies before the time limits laid down in Rule 31(2) expire.

Guid. A-IV, 4.2

- 80** From the date of publication of the European patent application (see point 150), the deposited material is available to anyone on request, but only if the requester makes certain undertakings to the applicant or proprietor regarding restrictions on the transmission and use of the material.

R. 33

Until the technical preparations for publication of your application are deemed to be complete (see point 149), you may inform the EPO that, for a certain period, the only way the biological material can be accessed is by the issue of a sample to an expert. This may be an expert appointed by mutual agreement between you and the requester, or a person chosen by the requester from a list of experts recognised by the President which is published in the Official Journal. The "expert" option is mentioned in the published European patent application.

*R. 32
Guid. A-VI, 1.1, 1.3
OJ 1992, 470*

- 81** Requests for the issue of samples of biological material deposited under Rule 33 must be submitted on forms obtainable free of charge from the EPO. These forms can also be downloaded from the EPO website (*www.epo.org*). The completed forms must be sent to the EPO, which certifies them and transmits them to the competent depositary institution.

R. 33(4), (5)

Claims

- 82** The claims must define the matter for which protection is sought in terms of the technical features of the invention. They must be clear and concise and supported by the description.

*Art. 84
R. 43
Guid. C-III, 1*

- 83** Wherever appropriate, claims should consist of two parts (see the examples in Annex III), a prior art portion and a characterising portion. In the first claim and all other independent claims, the prior art portion should designate the subject-matter of the invention and the technical features which are needed to define it but which, in combination, form part of the prior art. The characterising portion should state the

*R. 43(1)(a), (b)
Guid. C-III, 2*

technical features for which protection is sought in combination with the features in the prior art portion.

- 84** An "independent" claim must state all the essential features of the invention. *R. 43(3)*
Guid. C-III, 3.4, 3.7, 3.8, 4.5
- 85** A European patent application may not contain more than one independent claim in the same category (e.g. product and/or process) unless one of the exceptions listed in Rule 43(2) applies. *R. 43(2)*
OJ 2002, 112
- 86** Each independent claim may be followed by one or more "dependent" claims concerning particular embodiments of the invention. *R. 43(3), (4)*
Guid. C-III, 3.4, 3.5, 3.6
- Dependent claims should include all the features of the claim to which they relate. They must contain, if possible at the beginning, a reference to this other claim, which may also be dependent, and then state the additional features for which protection is sought.
- As far as possible, all dependent claims referring back to one or more previous claims must be grouped together in the most appropriate way.
- 87** As Article 84 requires claims to be concise (a requirement that applies both to the claims in their entirety and to each claim individually), you must keep the number of claims reasonable in consideration of the nature of the invention you wish to protect. You should therefore avoid undue repetition resulting from the use of independent claims in the same category or a proliferation of dependent claims. *R. 43(5)*
Guid. C-III, 5
- 88** You must number your claims consecutively in Arabic numerals. *R. 43(5)*
- 89** It is essential to formulate your claims clearly, as they define the matter that you want to protect. *Art. 84, 69*
Guid. C-III, 4.1
- The wording you use in claims must leave no doubt as to their meaning and scope, and you must avoid any inconsistencies between the description and the claims. *Guid. C-III, 4.2-4.9*
- The area defined by the claims must be as precise as the invention allows. As a general rule, claims which attempt to define the invention in terms of the result to be achieved are not allowed. Where the invention relates to a chemical product, it may be defined by its chemical formula or as a product of a process or, exceptionally, in terms of its parameters. *Guid. C-III, 4.10-4.16*
- Furthermore, references to the description or drawings, particularly in the form of "as described in part ... of the description" or "as illustrated in figure ... of the drawings", are not allowed unless they are absolutely indispensable. *R. 43(6)*
Guid. C-III, 4.17
- 90** However, in a European patent application containing drawings, reference signs linking the claims to the drawings should be placed in brackets after the technical features mentioned in the claims if this makes the claims easier to understand. They must not be construed as limiting the claims. *R. 43(7)*
Guid. C-III, 4.19
- 91** In exceptional circumstances, a European patent application or patent may include separate sets of claims for specific designated states (see point 102).

Claims incurring fees

- 92** If your European patent application comprises more than ten claims, you must pay a claims fee in respect of each claim over and above that number. You must pay claims fees within one month of filing the first set of claims. *R. 45(1), (2)*
Guid. A-III, 9

If your application includes several sets of claims (see point 102), a fee is payable only in respect of each claim beyond the tenth in the set that contains the greatest number of claims.

If you fail to pay the fees in due time, you may still validly pay them within a non-extendable period of one month after being notified of your failure to observe the time limit. If you do not pay the fees within this period, the claims for which you have not paid the fees are deemed to be abandoned, and you are notified accordingly (but see point 225). *R. 45 (2), (3)*
R. 112(1)
Guid. A-III, 9

- 93** If your application contains more than ten claims at the time of *grant*, claims fees are payable at this stage if they have not already been paid. If you do not pay them in due time, your application is deemed to be withdrawn (see points 165, 168). *R. 71(6), (7)*
Guid. C-VI, 14.1

Drawings

- 94** The requirements governing the representation of your invention in the drawings are set out in Rules 46, 48 and 49. Reference signs not mentioned in the description and claims must not be used in the drawings, and vice versa. The same features, when denoted by reference signs, must be denoted by the same signs throughout the application. *R. 46, 48, 49*
Guid. A-X
Guid. C-II, 5

- 95** Drawings must not contain text matter except, when absolutely indispensable, keywords such as "water", "steam", "open", "closed", "section on AB" and, on electric circuits and block schematics or flow sheet diagrams, short catchwords indispensable for understanding. Any such keywords must be placed in such a way that they can be replaced by their translations without interfering with any lines of the drawings. *R. 46(2)(j)*
Guid. A-X, 8

- 96** Flow sheets and diagrams are considered to be drawings. *R. 46(3)*
Guid. A-X, 1

Abstract

- 97** The abstract merely serves for use as technical information. It may not be taken into account for any other purpose, such as interpreting the scope of the protection sought or applying Article 54(3). It must be so drafted that it constitutes an efficient instrument for searching in the particular technical field, particularly by making it possible to assess whether the European patent application itself needs to be consulted. *Art. 85*
R. 47(5)
Guid. B-XI, 1, 2

- 98** The abstract, which must be preceded by the title of the invention, must contain a concise summary (preferably no more than 150 words long) of the disclosure as contained in the description, claims and drawings. It should indicate the technical field to which the invention relates, unless that is already clear from the title, and should be so drafted as to allow a clear understanding of the technical problem, the gist of the solution of that problem through the invention and the principal use of the invention. *R. 47(1)-(3)*
Guid. B-XI, 3

99 If your application contains drawings, you must indicate the figure or, exceptionally, figures which you suggest should accompany the published abstract. In this case each main feature mentioned in the abstract and illustrated in the drawing must be followed by the corresponding reference sign in parentheses.

R. 47(4)
OJ 1982, 357

100 The definitive content of the abstract is determined by the examiner (see point 148). Once the abstract has been published as part of the European patent application (see point 149), it is not amended again.

R. 66

Prohibited matter

101 Your application must not contain statements or drawings that are contrary to *ordre public* or morality. Nor should it contain statements disparaging the products or processes of any third party, or the merits or validity of any third party's applications or patents. Mere comparisons with the prior art are not considered disparaging *per se*. Furthermore, no statements should be made which are obviously irrelevant or unnecessary under the circumstances.

R. 48
Guid. A-III, 8
Guid. C-II, 7

Unitary character of European patent applications and patents

102 European patent applications and European patents have a unitary character, which means that the text and any drawings are uniform for all designated contracting states.

Art. 118
Guid. C-III, 8

The exceptions to this principle are as follows:

(a) If the EPO is informed of the existence of a prior right under Article 139(2), the European patent application or patent may, for such state or states, contain different claims and, if the examining division considers it necessary, different descriptions and drawings.

R. 138
Guid. C-III, 8.1

(b) If it is adjudged by a final decision that a third party is entitled to be granted a European patent in respect of only one part of the matter disclosed in the European patent application, the original European patent application must, for the designated states in which the decision was taken or recognised, contain claims, descriptions and drawings which, where necessary, are different from those for the other designated contracting states.

R. 18(1), (2)
Guid. C-III, 8.2

103 National rights of earlier date do not form part of the state of the art for the purposes of the EPO's examination for patentability (see point 34, last paragraph).

Guid. C-III, 8.4

However, during substantive examination (see point 173) or opposition proceedings (see point 182) you may, on your own initiative, submit separate claims for each designated contracting state in which an earlier national right exists, provided that you supply evidence of its existence to the examining or opposition division as appropriate. In such cases the examining or opposition division examines only the admissibility of the separate claims; it does not have to judge whether you have adequately limited the scope of your application in relation to the earlier national right. What it does examine, however, is whether the invention identified in the separate claims meets the patentability requirements of the EPC.

III. Filing European patent applications

Where to file

104 You can file European patent applications Art. 75(1), (2)

(a) with the EPO in Munich, its branch at The Hague or its sub-office in Berlin, but not at its sub-office in Vienna.

(b) with the central industrial property office or other competent authority of a contracting state if the law of that state so permits or prescribes.

Divisional applications must however be filed direct with the EPO. Art. 76(1)

105 The EPO's addresses are given in Annex IV. The addresses of the national patent authorities and national provisions of the contracting states governing compulsory or optional filing of European patent applications with such authorities are given in "**National law relating to the EPC**" (see point 4 above).

How to file

106 You must file applications **in written form**, either in person, by post, fax or online. *R. 1, R. 2, R. 35(1)
Guid. A-II, 1
Special edition
No. 3, OJ 2007, A.3.
and 4.
National Law relating
to the EPC*

You can file by fax with the EPO, and with the competent national authorities of those contracting states which so permit. Filing by fax is permitted by all the contracting states with the exception of Cyprus (CY), Estonia (EE), Hungary (HU), Italy (IT), the Netherlands (NL), Romania (RO), and Turkey (TR) (December 2007).

107 Similarly, you can file European patent applications **online** or on an electronic data carrier, using software issued by the EPO (Online Filing software; *www.epo.org*). You can also file European patent applications in electronic form with the competent national authorities of the contracting states which so permit. *Guid A-II, 1.3
Special edition
No. 3, OJ 2007, A.4.
OJ 2003, 610,
National Law relating
to the EPC*

You **cannot** file European patent applications with the EPO by e-mail, telegram, telex or teletext. *OJ 2000, 458*

108 As the EPO uses an automatic scanner system to capture European patent applications for printing, you are urged to use a machine-readable typeface for your applications. *OJ 1993, 59*

Confirmation on paper

109 If you file your application electronically (online or on CD-R, DVD-R or DVD+R) or by fax, you do not need to supply paper confirmation unless you are requested to do so. The EPO normally requires paper confirmation only if the documents so communicated are of inferior quality. *OJ 2002, 544*

When filing paper confirmation, you should indicate clearly that the document constitutes "confirmation of a document filed on ... by fax".

Date of receipt

110 The date of filing accorded to applications filed in person at the EPO is the date on which they are handed in or posted in one of the EPO's automated mailboxes. *Art. 80, R. 40
OJ 1992, 306*

The date of filing accorded to applications sent to the EPO by post is the date on which they are received.

The date of filing accorded to applications filed electronically or by fax is the date on which the application documents are received at the EPO or the competent national authority, provided the documents comply with the requirements of Article 80 (see point 136).

The above rules similarly apply to applications filed with the competent national authorities of the contracting states.

OJ 2002, 548

Acknowledgement of receipt

- 111** The authority with which you file your application acknowledges receipt without delay by sending you page 8 of the Request for Grant, on which it notes the date it received the application documents and the number of the application.

R. 35(2)
Guid. A-II, 3.1
OJ 1992, 306, 310

On request, the EPO will also issue fax acknowledgement that it has received your documents, provided that

- you enclose the request for fax acknowledgement with your documents
- you indicate the postal or fax address to which the acknowledgement is to be sent, and
- you provide evidence of payment of the prescribed administrative fee (see Annex VII) or enclose a debit order.

If you file online, receipt is acknowledged electronically during the submission session. If you file on CD-R, DVD-R or DVD+R, receipt is acknowledged by post.

OJ 2002, 545, item 8

Applications filed with national authorities and forwarded to the EPO

- 112** If an application you file with a national authority is forwarded to the EPO, the EPO notifies you accordingly, indicating the date it received it, by sending you a copy of the receipt for documents (page 8 of the Request for Grant). National authorities inform the EPO without delay when they receive applications.

R. 35(3)
Guid. A-II, 3.2
OJ 1990, 306

You are also sent an acknowledgement of receipt pursuant to Rule 35(3), signed by the national authority concerned, if you file European patent applications electronically with any of the national authorities.

- 113** In the very rare event that your application fails to reach the EPO before the end of the fourteenth month after filing or after the earliest priority date, it is deemed to be withdrawn, and any fees that you have paid are refunded. The EPO notifies you accordingly, and you can then convert your European patent application into national applications.

Art. 77(3)
R. 112(1)
Guid. A-II, 1.7, 3.2

You must file the request for conversion with the central industrial property office of the contracting state in which you filed the application, and you must do so within three months after receiving notification from the EPO. For more details see "**National law relating to the EPC**" (see point 4).

Art. 135(2)

Fees

- 114** The following fees are payable in respect of a European patent application:
- Art. 2 RFees
Guid. A-IV, 1.4
Guid. A-XI*
- (a) filing fee
 - (b) search fee
 - (c) claims fee (where appropriate) (see points 92, 93)
 - (d) designation fees
(one for each contracting state; if you pay seven times the amount of the fee, you are deemed to have paid designation fees for all the contracting states; for the joint designation of Switzerland and Liechtenstein only one fee needs to be paid, see point 39)
 - (e) extension fees (where appropriate) (one for each extension state, see point 26) *Guid. A-III, 12.2*
 - (f) examination fee (see point 152)
 - (g) renewal fees in respect of the third and each subsequent year (see points 213-218)
- 115** After filing the application you must pay the filing and search fees (and any claims fees required, where claims were filed together with the application) within one month of the date of filing. *Art. 78(2), R. 38*
- You must pay the designation fees (and any extension fees) within six months of the date on which the European Patent Bulletin mentions publication of the European search report. *Art. 79(2), 94(1)
R. 39,
R. 70(1)*
- The examination fee is payable within the same period.
- An overview of important deadlines for filing a European patent application, including deadlines for the payment of fees, is contained in Annex VI of this Guide and in Form 1034, obtainable from the EPO or the EPO website at www.epo.org.
- The EPO will not send you invoices or reminders to pay these fees in due time.
- 116** If you fail to pay the filing and search fees in due time, your European patent application is deemed to be withdrawn. *Art. 78(2)
Guid. A-III-13*
- If you fail to pay the designation fee for a contracting state in due time, the designation of that state is deemed to be withdrawn. If no designation fee is paid in due time, the application is deemed to be withdrawn (but see point 225). If you fail to pay the extension fee in due time, the request for extension to this state is deemed to be withdrawn. *R. 39(2), (3)
Guid. A-III, 11.5
Guid. A-III, 12.2*
- 117** For the payment of claims fees due in respect of the eleventh and each subsequent claim, see points 92 and 93. *R. 45
Guid. A-III, 9*
- 118** For the examination fee, see points 152 and 153.

119 In the case of European divisional applications (see points 208-212), you must pay the filing and search fees (and any claims fees) within one month after filing. You must pay the examination fee, the designation fees and any extension fees within six months of the date on which the European Patent Bulletin mentions publication of the European search report on the divisional application.

*R. 36(3), (4), 70(1)
Guid. A-IV, 1.4*

120 You should note that, if you fail to observe the above-mentioned time limits for payment of the filing fee, search fee or designation fees, further processing is available within two months of a communication from the EPO concerning the loss of rights on payment of the outstanding fee and the prescribed fee for further processing (see point 225).

*Art. 121
R. 135 (1)
Guid. A-III, 13
Guid. A-III, 11.3
Guid. A-III, 12.2*

Fee amounts and payment methods

121 Fee amounts, payment methods and effective payment dates are governed by the Rules relating to Fees (RFees) and by measures adopted by the President of the EPO implementing certain provisions of those Rules.

*Art. 2, 5, 7 RFees,
Arrangements for
deposit accounts
(ADA²)
Guid. A-XI*

Guidance on fee payment is published in each issue of the EPO's Official Journal, so you should consult the latest issue to find out the current situation.

122 The following advice and recommendations on paying fees to the EPO should be noted:

(a) Fees due to the EPO must be paid in euros.

*Art. 5 RFees
Guid. A-XI, 2
OJ 2007, 397*

Fees, including those for a European patent application filed with a national authority, must be paid direct to the EPO (for the only exception see (e) below). You can do this by paying them into or transferring them to a bank account held by the EPO³ or by debiting a deposit account you have opened with the EPO. The option of paying by cheque made payable to the European Patent Office is available until the end of March 2008.

(b) Depending on how you pay, the deemed date of payment is the day on which

Art. 7 RFees

- the amount of the payment or transfer is actually credited to a bank account held by the Office, or
- the order to debit a deposit account is received at the EPO.

It is advisable to pay fees as promptly as possible, preferably at the same time as filing your application.

(c) If a payment is received after expiry of the period within which it should have been made, the period is considered to have been observed if you can prove to the Office that:

*Art. 7(3) RFees,
Point 6.8 ADA
Guid. A-XI, 6.2*

in a contracting state, within the relevant period for payment,

- you effected the payment through a banking establishment, or

² Supplement to OJ 10/2007

³ The EPO publishes a list of accounts in every issue of its Official Journal and on its website (www.epo.org).

- you duly gave an order to a banking establishment to transfer the relevant amount, or
- you despatched at a post office a letter addressed to the Office and containing an order to debit a deposit account opened with the EPO, provided that there are sufficient funds in the deposit account on the date on which the period for payment expires
- and you have paid a surcharge of 10% on the relevant fee or fees, but not exceeding EUR 150; no surcharge is payable if you took one of the actions listed above no later than ten days before expiry of the period for payment.

The Office may request you to produce evidence of the date on which you took one of the actions listed above, and where necessary to pay the surcharge, within a period which it specifies. If you fail to comply with this request, if you produce insufficient evidence, or if you fail to pay the required surcharge in due time, the period for payment is considered not to have been observed.

Art. 7(4) RFees

- (d) If you pay fees through a banking establishment, you may use the bank of your choice. Payments and transfers must be to one of the accounts of the EPO.
- (e) If you file a European patent application with the EPO or a national authority and have a deposit account with the EPO, you can pay fees due on filing simply and securely by debiting your deposit account; you merely have to fill in the appropriate section of the fee payment form (EPO Form 1010) that you enclose with the application.

*Art. 7(2) RFees,
Point 6.9 ADA
Guid. A-XI, 3.3*

The EPO also accepts debit orders issued by fax or filed electronically. For more information about online fee payment, go to EPO Online Services on the EPO website (www.epo.org).

Point 6.2 ADA

If you are an EPO deposit account holder, you also have the option of issuing an automatic debit order (using section 42 of the Request for Grant, Form 1001, see Annex).

*ADA, Annexes A.1
and A.2
Guid. A-XI, 4.4
Point 6.10 ADA*

If you file your application with a national authority and the EPO does not receive the enclosed debit order until after the period for fee payment has expired, you are deemed to have met the time limit if there were sufficient funds in your deposit account on the date when the time limit expired.

- (f) Regardless of how you choose to pay, it is advisable to use the fee payment form (Form 1010, see Annex) to communicate particulars concerning payments. You can obtain the form free of charge from the EPO or from the central industrial property offices of the contracting states, or you can download it from the EPO website (www.epo.org).

IV. Filing other documents

Where and how to file

- 123** After you have filed a European patent application, you may file other documents as referred to in Rule 50 EPC with the EPO in Munich, The Hague or Berlin, either by hand or by post. The EPO provides forms which serve either as a prepared acknowledgement of receipt (Form 1037) or as letter accompanying subsequently filed documents (Form 1038). *R. 50*
Guid. A-IX, 2.5

You may also file documents (other than authorisations and priority documents) by fax. In grant proceedings, documents (other than priority documents) may also be filed electronically, using the EPO's Online Filing software. Such documents may not be filed by e-mail, on diskette, or by teletex, telegram, telex or similar means. *OJ 2003, 609*

- 124** If you filed the application with a national authority, you may likewise file all other documents relating to the application with that authority, subject to any restrictions under national law, but only until the date on which you receive notification that the EPO has received your application. Once you have received this notification, you must file any such documents with the EPO direct. *R. 35(4)*
Guid. A-II, 3.2

Signature

- 125** With the exception of annexes, any documents filed after filing of the European patent application must be signed. The signature may take the form of a handwritten signature, reproduction of the filer's signature (on faxes) or, in the case of online filings, by facsimile, text string or electronic signature. The name and position of that person must be clear from the signature. *R. 50(3)*
R. 2(2)
Guid. A-IX, 3.3

If the signature is omitted from a document, the EPO will invite the party concerned to sign within a fixed time limit. If signed in due time, the document retains its original date of receipt; otherwise it is deemed not to have been received. *Guid. A-IX, 3.1*

Confirmation on paper

- 126** If you file documents by fax, you must, if invited to do so by the EPO department charged with the procedure, supply written confirmation reproducing their contents and complying with the EPC Implementing Regulations within a non-extendable period of two months. If you fail to comply with this invitation in due time, the fax is deemed not to have been received (see point 109). *OJ 2005, 44*
Guid. A-IX, 2.5

Date of receipt

- 127** The rules governing the filing of the European patent application set out in point 110 apply *mutatis mutandis* to the filing of other documents. The date of filing accorded to documents filed by fax is the date on which they are received in full; save as provided for in point 124, all other documents relating to the application may only be filed with the EPO. *OJ 2005, 41*

Acknowledgement of receipt

- 128** The EPO acknowledges receipt of subsequently filed items on the forms provided for this purpose and completed by the applicant (EPO Forms 1037 and 1038).

OJ 2005, 41

For the possibility of obtaining an acknowledgement of receipt by fax see the second paragraph of point 111.

Guid. A-II, 3.1

D. The European patent grant procedure

I. General survey

129 The European patent grant procedure is an examination procedure beginning with a formalities examination and a mandatory search.

The first stage ends with the publication of the European patent application and the search report.

At the applicant's request this is followed by the second stage, substantive examination.

After the patent has been granted, there may be a third stage in the form of opposition proceedings or, upon request of the patentee, limitation or revocation proceedings.

130 The **first stage of the procedure** comprises an examination on filing, formalities examination, preparation of the European search report and a preliminary opinion on patentability, and publication of the application and the search report. Responsibility for this stage rests with the Receiving Section and a search division.

*Art. 16, 17, 90-93
R. 55-69
Guid. A, B*

131 The **second stage** comprises substantive examination and grant. Examining divisions are made up of three technically qualified examiners, who may if necessary be joined by a legally qualified examiner. Until a decision has to be taken on the application, its examination is as a rule entrusted to one of the technically qualified examiners. This examiner is responsible for issuing the requisite communications and for discussing the application with the applicant in writing, in person or on the telephone.

*Art. 18, 94-98
R. 71-74
Guid. C-VI*

If oral proceedings are requested by the applicant or (in exceptional cases) arranged at the Office's initiative, they are held before the full examining division. The final decision on the grant of the patent or refusal of the application is also a matter for the full examining division.

*Art. 116
Guid. E-III*

132 The **third stage**, which may or may not take place, consists of opposition proceedings, involving third parties such as competitors as opponents. Responsibility for examining oppositions rests with the opposition divisions, which are composed in the same way as the examining divisions, except that only one member of the opposition division is allowed to have been involved in the earlier grant proceedings, and that member is not allowed to chair the division.

*Art. 19, 99-105
R. 75, 89
Guid. D*

133 The third stage may also consist of revocation or limitation proceedings initiated by the patent proprietor himself. At any time after the grant of the patent the patent proprietor may request the revocation or limitation of his patent. Decisions on the revocation or limitation of European patents are taken by the examining divisions. More details about revocation and limitation proceedings can be found in points 189-196.

*Art. 105a-c
R. 90-96*

134 Appeal proceedings constitute a **special stage of the procedure**. Appeals may be filed against decisions taken by the Receiving Section, the examining divisions, the opposition divisions or the Legal Division.

*Art. 106-112
R. 99-103
OJ 2003, 61*

A decision which does not terminate proceedings as regards one of the parties can only be appealed together with the final decision, unless the decision allows separate appeal.

Decisions on appeals are taken by the boards of appeal.

Art. 21

- 135** In certain cases it may be possible to file a petition for review by the Enlarged Board of Appeal. For further details, see point 207.

Art. 112(a)
R. 104-110

II. Procedure up to publication of the application

Examination on filing

- 136** On receiving an application the Receiving Section examines whether it can be accorded a date of filing. This is the case if the application documents contain:

Art. 80, 90
R. 40
Guid. A-II, 4.1

- an indication that a European patent is sought
- information identifying the applicant
- a description or a reference to a previously filed application

- 137** It is not necessary to file any claims in order to obtain a date of filing. You may file claims within two months from the date of filing or from an invitation requesting you to do so. However, you should take care not to extend the scope of the subject-matter in the application if the claims are filed later.

Art. 123
R. 57(c)
R. 58
Guid A-III,9

- 138** If a date of filing cannot be accorded because any deficiencies found have not been remedied in due time despite an invitation to do so, the application will not be dealt with as a European patent application. For a date of filing to be accorded, the documents do not have to meet any particular requirements as to form or presentation. It is essential, however, that they be sufficiently legible to enable the information to be discerned.

Art. 80, R. 55
Guid. A-II, 4.1.4

- 139** Once the date of filing has been accorded, the Receiving Section examines whether the filing and search fees have been paid in due time and whether a translation of the application into the language of the proceedings, if required, has been filed in due time (see points 114, 115 and 42-46). If the filing fee or search fee has not been paid in due time, the European patent application is deemed to be withdrawn. However, see point 225 for the possibility of further processing.

Art. 78(2), 90(1), (3)
Guid. A-III, 13
Guid. A-III, 14
Art. 14(2)
R. 58

Formalities examination

- 140** If the application has been accorded a date of filing and is not deemed to be withdrawn, the Receiving Section checks for compliance with the provisions governing translations, the content of the Request for Grant (see point 48), the presence of claims (see point 92, 137), the filing of the abstract (see points 47 and 97-100), representation (see points 58- 66), formal requirements (see point 70), any priority claimed (see points 52-56), designation of the inventor (see points 49-51) and the filing of any drawings. If the Receiving Section finds correctable deficiencies, it invites you to remedy them (see points 66 and 208-212); if you fail to do so, the legal consequences provided for in the EPC take effect, i.e. the application is deemed to be withdrawn or is refused.

R. 57-60
Guid. A-III
Guid. E-I
Guid. E-II

- 141** If the deficiencies relate to a claim for priority and are not correctable, or if you do not remedy them although invited to do so, you lose your right of priority.

R. 59
Guid. A-III, 6
A-III, 16.2

A distinction must be made between failure to indicate the date or country of the prior application(s) within the 16-month time limit and failure to meet other requirements. Only deficiencies relating to the latter requirements are correctable.

- 142** If parts of the description or drawings referred to in the description or the claims are missing on the date of filing but are filed subsequently, you have a choice between re-dating the application to the date when the missing parts of the description or the drawings are filed and deleting the late-filed parts of the description or drawings together with references to them in the application. However, the first option is available only within two months from the date of filing or, alternatively, within a two-month time limit set in an invitation. The second option is available only within one month from the notification of the new date of filing. If the missing parts are completely contained in the priority document, no re-dating of the filing date is necessary.

R. 56
Guid. A-V, 2, A-II, 5
Guid. C-VI, 3.1

- 143** With regard to the requirements governing documents filed after the filing of the European patent application see points 123-128 and 171-176.

European search report

- 144** While the formalities examination is in progress, the European search is performed. As already mentioned (point 17), the EPO will make every effort to speed up the search if you request this when filing the application (see Annex II, point 2). For European first filings see point 18.

Art. 92
R. 61
Guid. B
OJ 2001, 459

The search report is drawn up on the basis of the claims, with due regard to the description and any drawings. It mentions the documents available to the EPO when it is drawn up which may be taken into consideration in assessing novelty and inventive step.

The search report is accompanied by an opinion on whether the application and the invention to which it relates meet the requirements of the EPC.

R. 62
R. 70
R. 71(1), (3)
Guid. C-VI, 1.1.2
Guid. B-XII, 8

The opinion is not issued if you have waived your right to receive the communication under Rule 70(2) EPC (see point 158) before the search report has been communicated to you. In this situation you will receive a first communication from the examining division instead.

The non-binding opinion is not published together with the search report but is available to the public by way of file inspection after publication of the application.

R. 62(2), Art. 128

- 145** Immediately after it has been drawn up, the European search report is transmitted to you together with copies of any cited documents. If you require a second copy of the documents, you can obtain it by indicating it in the appropriate box on the Request for Grant form (refer to point 48 and section 39 of the Request for Grant) when filing the application and by paying the prescribed administrative fee.

Art. 92(2)
R. 65
Guid. B-X

- 146** Having received the search report, you may withdraw the application if you think it has no chance of success. If you decide to pursue the

patent grant procedure (see point 155), you will have an opportunity to amend the application to reflect the results of the search (see points 171-176).

- 147** If the search division considers that the application does not comply with the requirement of unity of invention (see point 69), it draws up a European search report on those parts which relate to the invention first mentioned in the claims. It informs you that, if the search report is to cover the other inventions, you must pay a further search fee in respect of each of them within a period that it specifies.
- Art. 82
R. 64
Guid. B-VII
Guid. C-III, 7.9
- If you do not respond to this invitation, and if the examining division considers the search division's objection justified, you are deemed to want the application to proceed in respect of the invention for which the search report has been drawn up. The application must not include claims for subject-matter for which a further search fee has not been paid. You may however file a divisional application for such subject-matter (see points 208-212).
- Guid. C-III, 7.10
Guid. C-VI, 3.3.4
- Any further search fees paid will be refunded on request if it emerges during examination proceedings that the search division's payment demand was not justified.
- 148** Upon drawing up the European search report, the search division determines the definitive content of the abstract and transmits it to you together with the search report.
- R. 47
Guid. B-X, 7
Guid. B-XI, 4-6
- III. Publication of the European patent application**
- 149** The European patent application is published without delay once eighteen months have elapsed since the date of filing or the earliest priority date. You may however request that it be published earlier.
- Art. 93
Guid. A-VI
- The publication contains the description, the claims and any drawings, all as filed, plus the abstract. If the European search report is available in time, it is annexed (A1 publication); if not, it is published separately (A3 publication). A European patent application which was not filed in English, French or German is published in the language of proceedings.
- Guid. A-VI, 1.3
Guid. A-VI, 1.5
- All European patent applications, European search reports and European patent specifications are published in electronic form only, on the EPO's publication server. The publication server is accessible via the EPO website (www.epo.org).
- Guid. A-VI, 1.4
- 150** If you amend the claims after receiving the European search report but before completion of the technical preparations for publication (see point 172), the amended claims will be published in addition to the claims as filed. The technical preparations are deemed to have been completed five weeks before expiry of the eighteenth month after the date of filing or, if priority is claimed, after the date of priority.
- R. 68(3)
OJ 2006, 405
- 151** The European patent application is not published if it has been finally refused or withdrawn or deemed withdrawn before completion of the technical preparations for publication.
- R. 67(2)
Guid. A-VI, 1.2
OJ 2006, 405
- 152** The EPO informs you of the date on which the European Patent Bulletin mentions publication of the European search report, and it draws your attention to the period for filing the request for examination (paying the fee for examination), which begins on that
- R. 69
Guid. A-VI, 2.1

date (see point 155). It also informs you that the designation fees must be paid within six months of the date on which the European Patent Bulletin mentions publication of the European search report. You are not entitled to base any claims on the omission of this communication.

- 153** For the provisional protection that the application confers after publication see the third paragraph of point 5. Art. 67

A contracting state not having the language of the proceedings as an official language may prescribe that provisional protection does not take effect until a translation of the claims into one of its official languages at your option or, where that state has prescribed the use of one specific official language, in that language: Art. 67(3)

- (a) has been made available to the public in the manner prescribed by national law, or
- (b) has been communicated to the person using the invention in that state. The contracting states all make provisional protection conditional upon a translation of the claims. The same applies to the extension states (see point 26). For more information you are referred to "**National law relating to the EPC**" (see point 4).

- 154** Once the European patent application has been published, files relating to it are available for public inspection by way of the European Patent Register, which can be accessed via the EPO website (see also point 80). Art. 128(1)-(4)
R. 143
R. 144

From that time, too, the public has access to the application's bibliographic data and to information about the state of the proceedings by means of the European Patent Register, which can be accessed via the EPO website (see Annex VIII). Art. 127
R. 143
Guid. A-XII
OJ 2001, 249
OJ 2003, 23, 69

Additional information about the form in which European patent applications and patents are published and about periodical EPO publications is given in Annex VIII. Art. 129

IV. Examination procedure

Request for examination

- 155** You need to file the request for examination within six months of the date on which the European Patent Bulletin mentions publication of the European search report (see point 151). The request, which you must submit in writing, is contained in the Request for Grant form (see section 5), but it is not deemed to be filed until you have paid the examination fee. Once filed, it cannot be withdrawn. Art. 94-98
R. 70-74
Guid. A-VI, 2.2
Guid. C-VI, 1.1
Art. 2 No. 6 RFees

If you do not validly file the request for examination within the time limit, the application is deemed to be withdrawn. However, the opportunity to request further processing is available (see point 225). Art. 94(2)
Guid. A-VI, 2.3
Guid. C-VI, 1.1

- 156** You always have the option of paying the examination fee when you file the application. No disadvantages can accrue from this, as the examination fee is refunded in full if the application is withdrawn, refused or deemed to be withdrawn before the examining division has assumed responsibility, and at a rate of 75% after that date but before substantive examination has begun. Art. 11 RFees
Guid. A-VI, 2.2, 2.5
Guid. C-VI, 1.1

- 157** If you validly file the request for examination before receiving the European search report, pursuant to Rule 70(2) the Receiving Section invites you to indicate, within six months of the date when the European Patent Bulletin mentions publication of the search report, whether you wish to proceed further with the application. If you do not reply to this invitation in due time, the application is deemed to be withdrawn.

*R. 70
Guid. A-VI, 2.3
Guid. C-VI, 1.1.1*

In this case, however, further processing is available (see point 225).

- 158** To speed up proceedings, you can also, for example in the Request for Grant form, simply waive your right to the invitation to confirm the request for examination. In that case, when you receive the search report you are deemed to have indicated that you wish to proceed further with the application, and the examining division then assumes responsibility for the procedure (see point 144 and Annex II, Programme for accelerated prosecution, point 5).

*Art. 18(1)
R. 70(2)
Guid. C-VI, 1.1.2
OJ 2001, 459*

Stages of the procedure

- 159** Once you have filed the request for examination, the EPO examines in the light of the search report whether the application and the invention to which it relates meet the requirements of the Convention, and in particular whether the invention is patentable (see points 27-37).

*Art. 94(1)
Guid. C-VI*

- 160** After receiving the search report and before receiving the examiner's first communication, you can file substantive observations on the search report and amend the description, claims and drawings (see point 172). This will speed up the processing of the application at the examination stage (see Annex II, point 6).

*R. 137(2)
Guid. C-VI, 3.1*

- 161** If the examiner responsible within the examining division has objections to the application, he sends you a first reasoned communication inviting you to file your observations and, if necessary, to submit amendments to the description, claims and drawings (see points 171-176).

*R. 71(1), 137(3)
Guid. C-VI, 2.4
Guid. C-VI, 3.2-3.8
Guid. E-I, E-II*

If you fail to reply in due time to this or any further communication, the application is deemed to be withdrawn (but see point 225).

Art. 94(4)

If your actions are clearly indicative of an interest in speedy substantive examination, the examiner will make every effort to issue the first communication within three months of the examining division's receipt of the application or the request for accelerated examination (see Annex II, point 4).

*Special edition
No 3, OJ 2007, F.1.*

You might also be invited to provide information on prior art taken into consideration in the examination of national or regional patent applications and concerning an invention to which the European patent application relates. If you do not provide this information within a specified time limit, the application is deemed withdrawn (but see point 225).

*Art. 124(2)
R. 141
Guid. C-VI, 2.3.1*

- 162** You must try to deal with all the examiner's objections, the guiding principle of the examination procedure being that the decision to grant a patent or refuse the application should be reached in as few actions as possible.

Guid. C-VI, 2.5

If, after examining your response, the examiner considers that the application is not yet grantable, he will continue with the examination procedure by issuing a further written communication or talking to you in person or on the telephone.

*Guid. C-VI, 4
Guid. C-VI, 6*

- You may at any time request oral proceedings. Art. 116
Guid. E-III
- 163** The examiner may seek the advice of other members of the examining division whenever he sees fit. At the latest he will refer the application to them when a decision has to be taken. Guid. C-VI, 4.4
Guid. C-VI, 7
- If the examining division is of the opinion that a European patent cannot be granted, it will refuse the application. The decision is issued by the examining division as a whole, and the grounds of refusal must be stated. Refusals may be based only on grounds on which you have had an opportunity to comment. Art. 97(1)
Guid. C-VI, 7.6, 7.7
Art. 113(1)
- 164** If the application and the invention to which it relates meet the requirements of the Convention, the examining division will decide to grant a European patent provided that the requisite fees have been paid in due time and a translation of the claims into the other two official languages of the EPO has been filed in due time. Art. 97(2)
R. 71(3)-(7)
Guid. C-VI, 14
- 165** The examining division informs you of the text in which it intends to grant the European patent, and invites you to pay the fees for grant and printing and any claims fees for claims in excess of ten which have not yet been paid, as well as to file a translation of the claims into the two official languages of the EPO other than the language of the proceedings within a non-extendable period of four months. Art. 97
R. 71(3)
Guid. C-VI, 14.1,
14.3
- If you pay the prescribed fees and file the necessary translations of the claims in due time, you are deemed to have approved the text intended for grant. If you fail to file the translations and/or to pay the fees for grant and printing and/or claims fees, the application is deemed to be withdrawn (but see point 225). R. 71(3), (7)
- 166** Upon reviewing the proposed text for grant, you may wish to make minor amendments, and/or you may discover mistakes. In that case you have an opportunity to file amendments or corrections within the period set under Rule 71(3) (see point 165). If the examining division consents to the amendments or corrections, it can immediately proceed to grant, as you are obliged to file translations of the claims as amended or corrected, provided you have also paid the fees for grant and printing within the time limit set. If you file amendments or corrections and translations of the claims in due time, but do not pay the fees or file the translation, the application is deemed to be withdrawn (but see point 225). R. 71(4), R. 137(3),
R. 139
Guid. C-VI, 4.9
Guid. C-VI, 14.4
OJ 2002, 114
- 167** If the examining division does not consent to the requested amendments or corrections, you are given an opportunity to comment, and either to withdraw or again to amend the amendments or corrections. In the latter case, amended translations of the claims need to be submitted once more to reflect the grantable text. As such amendments are generally of a minor nature, this should involve no substantial burden for you. R. 71(5)
Guid. C-VI, 14.4
- 168** If you fail to meet the objections raised, the examining division will refuse the application under Article 97(2) because it does not meet the requirements of the Convention. As you always have to pay the fees for grant and printing and any claims fees due within the time limit set under Rule 71(3), any fees you have paid will be refunded if no patent is granted. After you have received the communication under Rule 71(3), the above procedure does not take place until you have Art. 97(1)
R. 71
Guid. C-VI, 14.7

paid these fees. If you fail to pay them, the application is deemed to be withdrawn (but see point 225).

Before a patent can be granted, you must also have paid any renewal fee and additional fee due (see point 213 et seq.). If a renewal fee falls due before the expected date of publication of the mention of grant of the European patent, you will be informed accordingly. Mention of grant will not be published until you have paid the renewal fee. If you fail to pay the renewal fee and any additional fee in due time, the application is deemed to be withdrawn.

Art. 86(1)
R. 71(9)
Guid. C-VI, 14.2

169 If you overrun the period set under Rule 71(3) or (5), you may request further processing under Article 121 (see point 225).

Art. 121
R. 135
Guid. C-VI, 14.6

170 The grant does not take effect until the date on which it is mentioned in the European Patent Bulletin. At the same time as it publishes this mention, the EPO publishes a European patent specification containing the description, the claims and any drawings. The European Patent Bulletin is published electronically on the EPO's publication server (*www.epo.org*).

Art. 97(3), 98
Guid. C-VI, 14.8-11

A certificate for the European patent, with the specification annexed, will be issued on request.

R. 74

Amending applications before and during examination proceedings

171 You are not allowed to amend the description, claims or drawings before you receive the European search report.

R. 137(1)
Guid. A-V, 2
Guid. C-VI, 5
Guid. D-V, 6
Guid. E-II

172 After receiving the European search report and before receiving the first communication from the examining division, you may of your own volition amend the description, claims and drawings (see points 149, 160 and 175).

R. 137(2)
Guid. C-VI, 3.2, 3.3

173 After receiving the examiner's first communication, you may of your own volition amend the description, claims and drawings once, i.e. when replying to the communication. No further amendments are allowed without the examining division's consent. Amended claims may not relate to unsearched subject-matter which does not combine with the originally claimed invention to form a single general inventive concept. In deleting subject-matter from an application, you should avoid any statement which could be interpreted as abandonment of that subject-matter. Otherwise the subject-matter cannot be reinstated.

R. 137(3), (4)
Guid. C-VI, 4.7, 4.8
Guid. C-VI, 5.2

174 The Guidelines provide information about the limits to the amendments that you can make to the description, claims and drawings after receiving the communication under Rule 71(3). Once you have approved the text communicated to you pursuant to Rule 71(3) (including minor amendments and/or corrections of errors, see point 165) by filing the translations and paying the fees, further amendments will only exceptionally be allowed under the discretionary power given to the examining division by Rule 137(3).

R. 137(3)
Guid. C-VI, 4.9, 4.10

175 The application may on no account be amended in such a way that it contains subject-matter which extends beyond the content of the application as filed (which does not include the priority document). However, subsequently filed examples or statements of advantage

Art. 123(2)
Guid. C-II, 4.3
Guid. C-VI, 5.3

may be considered by the examiner as evidence in support of the invention's patentability.

This technical information is generally added to the part of the file that is open to public inspection (see point 154). From the date on which it is added, it forms part of the state of the art within the meaning of Article 54(2) (see point 32). A note is printed on the cover page of the patent specification to alert the public that information submitted after the application was filed is not included in the specification (see point 170).

Guid. C-VI, 5.3.6

176 You can make amendments to the European patent application in one of the following ways:

Guid. E-II

- (a) By filing replacement pages. You should use this method only if the amendments are extensive and complicated. If it is not immediately clear how or why an amendment is to be made, you should provide explanatory notes in the margin of the replacement pages or on separate sheets. You must comply with the provisions governing application document presentation (see point 70).
- (b) By annotating a copy of the relevant page(s) of the application. This is the preferred method if the amendments are not too extensive, as it simplifies checking. The amendments may be handwritten or typed; handwritten amendments must be clearly legible so as to avoid printing errors.
- (c) By indicating the changes in a letter. This method is suitable if, for example, you wish to delete whole pages, paragraphs or drawings.

National requirements governing translations of European patents

177 Any contracting state may make the protection conferred by a European patent granted (or amended or limited) in a language that is not one of its official languages contingent upon your filing a translation into one of its official languages or its prescribed official language. It may also require you to bear some or all of the cost of publishing the translation. The same applies to extension states.

Art. 65

For more details refer to "**National law relating to the EPC**" (see point 4 above).

You should take great care to comply with these requirements, especially those governing time limits for filing translations, so as not to undermine the protection conferred by the patent in the designated contracting states.

Art. 65(3)

V. Opposition procedure

Art. 99-105

R. 75-89

Guid. D

OJ 2001, 148

Opposition period

178 Up to nine months after publication of the mention that a European patent has been granted, anyone may give the EPO notice of opposition to the patent, except for the proprietor, who is not allowed to oppose his own patent.

Art. 99

OJ 1994, 891

Notice of opposition is not deemed to have been filed until the opposition fee has been paid.

Grounds for opposition

- 179** Opposition may only be filed on the grounds that:
- the patent's subject-matter is not patentable within the terms of Articles 52-57
 - the patent does not disclose the invention clearly and completely enough for it to be carried out by a person skilled in the art
 - the patent's subject-matter extends beyond the content of the application as filed.
- Art. 99(1)*
Art. 100
Guid. D-III, 5

Form and content of the notice of opposition

- 180** Notice of opposition must be filed in one copy within the opposition period in a reasoned statement. That means that the opponent must state at least one ground for opposition under Article 100 and indicate the facts, evidence and arguments presented in support of the ground(s). Otherwise the notice of opposition will be rejected as inadmissible. It is advisable to use the EPO opposition form (Form 2300), which provides all the information needed to ensure that an opposition is admissible. This form is available free of charge from the EPO and the central industrial property offices of the contracting states as well as via the EPO website (www.epo.org).
- Art. 99(1)*
R. 76
Guid. D-III, 3
Guid. D-III, 6

Notice of opposition may also be filed by fax (see points 123-128).

R. 2
Guid. D-III, 3.2

Examination of the notice of opposition for admissibility

- 181** Immediately after receiving the notice of opposition, the EPO communicates it to the proprietor and checks that it is admissible. Deficiencies in the notice are communicated to the opponent. Deficiencies under Rule 77(1) must be remedied within the opposition period. Other remediable deficiencies must be corrected within a period specified by the EPO (generally two months). If the deficiencies noted are not corrected in due time, the notice of opposition is rejected as inadmissible.
- R. 77*
Guid. D-IV, 1.2

Documents cited in support of the opposition or as evidence should be filed together with the notice of opposition. If this is not done, the Office invites the opponent to file them within a period that it specifies (generally two months). If the opponent fails to do so in due time, the opposition division may decide not to take any arguments based on them into account.

R. 83
Guid. D-IV, 1.2.2.1

- 182** Immediately after expiry of the opposition period or the period laid down for remedying deficiencies or presenting evidence, the patent proprietor is invited to file observations and, where appropriate, amendments within a period specified by the EPO (generally four months). Amendments are allowed only if they are occasioned by grounds for opposition under Article 100, including grounds not invoked by the opponent.
- R. 79*
Guid. D-IV, 5.2
R. 80
Guid. D-IV, 5.3

Substantive examination of the opposition

- 183** Once these preliminaries have been completed, the opposition division examines whether the grounds for opposition prejudice the maintenance of the European patent. If necessary it will invite the parties to file observations on its or other parties' communications within a period which it specifies.
- Upon receipt of a communication sent to him in this way, the proprietor may file the description, claims and drawings in amended form where necessary. Late-filed proposals for amendment may not be considered.
- If oral proceedings have to be arranged at the request of a party or at the instance of the EPO where it considers them expedient, the summonses are issued as soon as possible.
- In a note annexed to the summons, the opposition division lists and explains the points that in its view need to be discussed for the purpose of the decision that has to be taken. The note generally also includes the opposition division's provisional and non-binding opinion on the positions adopted by the parties, and in particular on amendments to the patent filed by its proprietor. At the same time, the opposition division fixes a final date for filing written submissions or amendments in preparation for the oral proceedings. New facts and evidence presented after that date may not be considered, unless admitted on the grounds that the subject of the proceedings has changed.
- 184** If the opposition division finds that the grounds for opposition prejudice the maintenance of the European patent, it revokes the patent. If it finds that the grounds do not prejudice the maintenance of the patent as granted, it rejects the opposition.
- 185** If the opposition division finds that the patent can be maintained in amended form, it delivers an interlocutory decision stating that, with the amendments made by the proprietor, the patent and the invention to which it relates meet the requirements of the EPC.
- An interlocutory decision of this nature, against which a separate appeal is allowed, is delivered whenever a patent is maintained in amended form.
- 186** Once the interlocutory decision becomes final, the proprietor is given three months in which to pay the fee for printing a new specification and file a translation of any amended claims in the two official languages other than the language of the proceedings.
- 187** If these acts are not performed in due time, they may still be validly performed within two months of notification of a communication pointing out the failure to observe the time limit, provided that a surcharge is paid within this period.
- If either of the acts is not performed within this period either, the patent is revoked.
- 188** The contracting states make the amended text subject to the same translation requirements as the patent specification (see point 177 and Annex V).
- Art. 101
R. 81
Guid. D-V, VI*
- R. 81(3)
Guid. D-VI, 4.2
Guid. E-II
E-VIII, 1.2*
- Art. 116(1)
R. 115
Guid. D-VI, 1*
- R. 116
Guid. D-VI, 3.2
Guid. E-III, 8.6*
- Art. 101
R. 81
Guid. D-VIII*
- Art. 101(3)(a)
R. 82
Guid. D-VI, 7.2*
- R. 82(2)
Guid. D-VI, 7.2.3*
- R. 82(3)*
- Art. 101(3)*
- Art. 65*

VI. Limitation and revocation procedure

Art. 105a-c
R. 90-96

- 189** As patent proprietor you may request the revocation or limitation of your own **patent**. **You can file the request at any time after grant**, after opposition proceedings or even after expiry of the patent. However, a request for revocation or limitation filed while opposition proceedings in respect of the European patent are pending is deemed not to have been filed, since the opposition proceedings have precedence. If limitation proceedings are pending at the time of filing of an opposition, the limitation proceedings are terminated and the limitation fee is reimbursed.
- 190** Requests must be filed direct with the EPO. The general provisions for filing a European patent application (see Rules 35 ff) and the need for professional representation for non-resident patent proprietors apply (see points 58-59). Furthermore, the request is deemed to be filed only when the limitation or revocation fee is paid.
- 191** The subject of limitation or revocation proceedings is the European patent as granted or as amended in opposition or (earlier) limitation proceedings. Since limitation is effected by means of amendment of the claims, the request must include a complete set of the amended claims (and the description and drawings if applicable). If these or the general requirements regarding languages and representation (see points 42-45 and 58-66) are not met, the Office invites you to correct any deficiencies within a period to be specified, normally of two months. If you do not correct the deficiencies within this period, the request is rejected as inadmissible. Re-establishment of rights is however available. The decision rejecting the request is open to appeal.
- 192** If the request is for **revocation** and is admissible, then the examining division revokes the patent and communicates this to the requester.
- The decision takes effect on the date on which it is published in the European Patent Bulletin.
- It applies ab initio to all contracting states in respect of which the patent was granted. It is not possible for the patent to be revoked for some contracting states and not for others.
- 193** If the request for **limitation** is admissible, the examining division proceeds with its examination of the request. The basis for the examination is the patent as granted or amended in opposition or limitation proceedings. Where there have already been both opposition and limitation proceedings, then the basis for the examination is the patent as amended in the most recent of the procedures. The examining division only examines whether the amended claims constitute a limitation with respect to the claims as granted or amended and whether they are clear and concise and supported by the description and do not contain subject-matter which extends beyond the application as filed.
- 194** The term 'limitation' means a reduction in the scope of protection of the claims. Clarifications or changes made simply to protect different subject-matter are not considered to be limitations. If there are any deficiencies, you will be invited to correct them within a period generally set to two months.

Art. 105a(2)
R. 93
Guid. D-X, 2.1.

Art. 105a(1)
R. 35 ff
Art. 2 No. 10a RFees

R. 90
R. 92(2)
R. 94
Guid. D-X, 2.2, 3
Art. 122

Art. 105b(2)
R. 95(1)
Guid. D-X, 4
Art. 105b(3)

Art. 64
Art. 67

R. 90
Art. 84
Art. 123(2), (3)

Art. 105b(1)
R. 95
R. 132(2)
Guid. D-X, 4.3-5

- 195** If the request for limitation is allowable, you will be informed accordingly and invited to pay the prescribed fee for an amended specification and to file a translation of the amended claims into the other two official languages within a period of three months. The procedure for this is the same as in opposition proceedings. If you pay the fees and file the translations as set out above in due time, then the examining division will limit the patent. If not, the request will be refused. The European patent specification as limited will be published and a new certificate issued to you.
- Art. 105b(2)
R. 95(3), (4)
Art. 2, No. 8 RFees
Guid. D-X, 5
Art. 105c
R. 96, 74*
- 196** The decision to limit the European patent takes effect on the date on which it is published in the Bulletin. The effect of the decision to limit the patent is that the patent is limited ab initio.
- Art. 105b(3)
Art. 68
Art. 21(3)(a)*
- VII. Appeals procedure**
- Art. 106-112
R. 99-103
Guid. E-XI*
- Filing an appeal**
- 197** Appeals may be filed against decisions of the Receiving Section, the examining divisions, the opposition divisions and the Legal Division. An appeal has suspensive effect, which means that the contested decision is not yet final (no formal *res judicata*) and its effects are suspended.
- Art. 106*
- 198** Notice of appeal must be filed in written form within two months after the date of notification of the contested decision. It is not deemed to have been filed until the appeal fee has been paid. Within four months after the date of notification of the decision, a written statement setting out the grounds of appeal must be filed. The above time limits cannot be extended. Further processing under Article 121 is excluded.
- Art. 108
R. 126
Art. 2, No. 11 RFees*
- 199** The notice of appeal and the statement of grounds may be filed by fax. The Registry of the boards of appeal as a rule requests written confirmation only if the quality of the document filed is deficient.
- R. 2
OJ 2003, 419*
- 200** The notice of appeal must contain:
- (a) the name and address of the appellant
(b) an indication of the appealed decision, and
(c) a request defining the subject of the appeal.
- Art. 107
R. 99, 100
R. 41(2)(c)*
- 201** In the statement of grounds the appellant should indicate the reasons why the decision should be set aside, or the extent to which it is to be amended. Similarly, the facts and evidence on which the appeal is based should also be filed. As appeal proceedings are in practice mostly conducted by written procedure, arguments should be presented in writing and not reserved for possible oral proceedings.
- The Registry gives each appeal its own reference number, which must be used throughout the appeal proceedings.
- Interlocutory revision**
- 202** If the department whose decision is contested considers an appeal to be admissible and well founded, it must rectify its decision within three months of receiving the statement of grounds. If the appeal is not allowed within that period, it must be remitted to the board of appeal without delay.
- Art. 109
Guid. E-XI, 7*

Interlocutory revision is not possible where the appellant is opposed by another party to the proceedings (in particular in opposition proceedings).

Stages of the procedure before the boards of appeal

- 203** The boards decide on appeals at second and, mostly, final instance. Their members are independent. In their decisions they are not bound by any instructions, and they must comply only with the EPC. The procedure before the boards is laid down in their Rules of Procedure, published in the Official Journal. Art. 23(3)
OJ 2003, 89, 419
- The technical boards of appeal are responsible for appeals against decisions of the examining divisions concerning the refusal of European patent applications or the granting of European patents and for appeals against decisions of the opposition divisions. Art. 21(3)(a), (4)
- The technical boards normally consist of three members (two technically qualified and one legally qualified). This is increased to five (three technically qualified and two legally qualified) if a legally qualified member was added to the department of first instance or if the board considers that the nature of the appeal so requires (enlarged composition - Article 21(3)(a) and (b)). Art. 21(3)(a), (b)
- Where the technical boards of appeal are not competent - particularly in the case of appeals against decisions of the Receiving Section or the Legal Division - a legal board of appeal consisting of three legally qualified members deals with such procedures. Art. 21(3)(c)
- 204** To ensure uniform application of the law or if an important point of law arises, referrals may be submitted to the Enlarged Board of Appeal. During proceedings on a case and either of its own motion or following a request from a party, a board of appeal may refer any question to the Enlarged Board if it considers that a decision is required for the above purposes. The Enlarged Board's decision is binding on the referring board. The President of the EPO may refer a point of law to the Enlarged Board if two boards of appeal have given different decisions on the issue. Art. 22
Art. 112
OJ 2007, 303
- 205** The provisions relating to proceedings before the department which took the appealed decision are essentially applicable *mutatis mutandis* to appeal proceedings and proceedings for petition for review. In the examination of the appeal, the board of appeal invites the parties to file, within a specified period, observations on communications issued by itself or observations submitted by another party. Art. 110
R. 100
- Oral proceedings may be held at the request of a party or at the instance of the EPO. Art. 116
- 206** In deciding on the appeal, the board may either exercise any power within the competence of the department which took the appealed decision or remit the case to that department for further prosecution. In the latter case, the department is bound by the board's *ratio decidendi*, in so far as the facts are the same. Art. 111
- ### Petition for review
- 207** Any party to appeal proceedings adversely affected by the decision of the board of appeal can file a petition for review of the decision by the Enlarged Board of Appeal. However, such petitions may only be filed Art. 112a
R. 104-107
Art. 113

on the grounds either that the composition of the board was not correct, or that a fundamental violation or any other fundamental procedural defect of the right to be heard had occurred, or that a criminal act may have had an impact on the decision. The objections must have been brought up during the appeal proceedings.

As a rule, petitions must be filed within two months of notification of the decision of the board of appeal. A petition is not deemed to be filed until the prescribed fee has been paid.

Art. 112a(4)
Art. 2 No. 11a RFees

If a petition for review is admissible and allowable, the Enlarged Board of Appeal sets aside the decision of the board of appeal and orders reopening of the proceedings before the responsible board of appeal as well as the reimbursement of the fee for petition for review.

Art. 112a(5)
R. 108
R. 110

VIII. Divisional applications

208 The usual reason for filing a European divisional application is that the parent application does not satisfy the requirements as to unity of invention (see point 69) and the applicant is not content with limiting it.

Art. 82
Art. 76
R. 36
Guid. A-IV, 1
Guid. C-VI, 9.1

209 A divisional application may be filed only for subject-matter which does not extend beyond the content of the parent application as filed. If it complies with this provision and with the formal requirements for according a date of filing (see point 136 et seq.), it is deemed to have the same date of filing and priority date as the parent application.

Art. 76(1), 2nd sentence
Art. 80
Guid. A-IV, 1.2
Guid. C-VI, 9.1.1

All the contracting states designated in the parent application at the time of filing of the divisional application are deemed to be designated in the latter. However, contracting states the designations of which have been withdrawn or are deemed to be withdrawn in respect of the parent application at the time of filing the divisional application cannot be designated in respect of the divisional application.

Art. 76(2)
Guid. A-IV, 1.3.4

210 A divisional application may be filed in respect of any pending earlier European patent application. An application is pending up to (but not including) the date on which the European Patent Bulletin mentions the grant of the European patent or the date on which the application is refused, withdrawn or deemed to be withdrawn.

R. 36(1)
Guid. A-IV, 1.1.1
OJ 2002, 112

211 Divisional applications must be filed direct with the EPO in Munich, The Hague or Berlin. They may also be filed using the EPO's Online Filing software. They must be filed in the language of the proceedings for the parent application.

R. 36(2)
Guid. A-IV, 1.3
Guid. A-VIII, 1.3.3

212 For the fees payable in respect of a European divisional application, and also for the time limits for payment and the legal consequences of missing them, see points 119-122.

The search fee is refunded in full or in part, depending on the extent to which the search can be based on the search report for the parent application.

Art. 9 RFees

If the divisional application is filed more than two years after the date of filing of the parent application, the applicant must pay outstanding renewal fees (see points 213-216) no more than four months after filing the divisional application. If these are not paid in due time, they may still be validly paid within six months of the due date, provided that the additional fee is paid within the time limit (see point 215).

R. 51(3)
Art. 86(1)

After filing, each divisional application is treated as an independent patent application.

IX. Renewal fees

- 213** You are required to pay renewal fees to the EPO in respect of your European patent application. These are due in respect of the third and each subsequent year, calculated from the date of filing. *Art. 86
Art. 2 No. 4 RFees
R. 51
OJ 1984, 272*
- 214** Renewal fees in respect of the coming year are due on the last day of the month in which the anniversary of the date of filing falls. For fee amounts and payment methods see points 121 and 122. *R. 51(1)*
- 215** Payment may still be validly made up to six months after the due date, provided that an additional fee equal to 10% of the belated renewal fee is paid within the same period. The EPO will normally send you a reminder; you are not, however, entitled to base any claims on the omission of this courtesy service. Renewal fees may not be validly paid more than one year in advance of the date on which they fall due. *R. 51(2)
Art. 2 No.5 RFees
Guid. A-XI, 5.2.4*
- 216** If you fail to pay the renewal fee and any additional fee in due time, the application is deemed to be withdrawn. Further processing under Article 121 is not available, but you may request re-establishment of rights under Article 122 (see also point 226). *Art. 86(1)
R. 135
R. 136*
- 217** The last renewal fee payable in respect of a European patent application covers the patent year in which the mention of the grant of the patent is published (see point 168 ff). *Art. 86(2)*
- 218** Renewal fees for subsequent years during the term of the European patent (see point 5, last paragraph) are payable to the central industrial property offices of the designated states. For more details refer to "**National law relating to the EPC**" (see point 4). *Art. 63
Art. 141*

X. General provisions governing periods

- 219** Annex VI contains charts illustrating actions applicants have to take within periods laid down in the EPC. *Art. 120-122
R. 131-136
Guid. E-VIII*

The principle is that a period is calculated from the day after the date on which the relevant event occurred. In the case of a notification, the event considered is the receipt of the document notified, subject to the provisions governing notification. The generally applicable procedure for notifications is indicated below. Period expiry is regulated in Rule 131(3)-(5). In certain special cases a period may be extended in accordance with Rule 134.

*R. 131
Guid. E-VIII, 1.4*

A period will be deemed to have been observed if a document received late was posted, or delivered to a delivery service recognised by the President of the EPO (Chronopost, DHL, Federal Express, flexpress, TNT, SkyNet or UPS), at least five calendar days before the relevant period expired, unless the document was received later than three months after the period expired.

*R. 133
Special edition
No. 3, OJ 2007, I.1*

- 220** A period set by the EPO may also be extended provided that a request for extension is submitted before it expires. However, a request for extension which would make the total period over six months long will be allowed only in special cases. R. 132(2)
Guid. E-VIII, 1.6
OJ 1989, 180
OJ 1994, 229
- 221** All decisions, summonses, notices and communications from which a period is reckoned are delivered as notifications. Art. 119
R. 125-129
Guid. E-I
R. 127
- As a rule, notification is effected by registered letter, which is deemed to be delivered on the tenth day following its posting unless it fails to reach the addressee or reaches him at a later date.
- Missed time limits**
- 222** By missing a time limit, you make yourself liable to **legal sanctions**, such as refusal of the application or total or partial loss of rights occurring without the Office taking a decision. Cases where the latter applies include loss of the right of priority due to late filing of the priority document, or the application being deemed withdrawn due to failure to reply to a communication from the EPO in due time. Guid. E-VIII, 1.8
- 223** Whenever the EPO finds that rights have been lost without taking a decision, it communicates this to you. R. 112(1)
Guid. E-VIII, 1.9.1,
1.9.2
- If you consider that the EPO's finding is inaccurate, you may, within two months after receiving the communication, apply for a decision on the matter. A decision will be taken only if the EPO stands by its opinion, and any decision taken is subject to appeal. If no decision is taken, the EPO will inform you that the loss of rights is cancelled. R. 112(2)
Guid. E-VIII, 1.9.3
- Completion of an omitted act**
- 224** The EPC makes provision for omitted acts to be completed, depending on the nature of the missed time limit. Guid. E-VIII, 2
- 225** If you miss a time limit vis-à-vis the EPO, it is generally sufficient to request further processing of the application. Further processing should be requested by payment of the fee within two months of the date on which the communication concerning either the failure to observe a time limit or a loss of rights is notified. The omitted act must be completed within that period. No reasons need to be given for the request. Further processing is ruled out in respect of certain time limits as listed in Article 121 and Rule 135(2). Art. 121
R. 135
Guid. E-VIII, 2.1
- 226** Re-establishment of rights (*restitutio in integrum*) is available for those time limits for which further processing is ruled out. However, this will be granted only if you were unable to meet the time limit despite taking all due care required by the circumstances. Art. 122
R. 136
Guid. E-VIII, 2.2
- If you act through a representative, your application for re-establishment will be granted only if the representative has taken the care demanded of the applicant in Article 122(1).
- 227** Re-establishment of rights is excluded in respect of time limits for which further processing is available and in respect of the period for requesting re-establishment of rights. Re-establishment of rights is however available in respect of the time limit for requesting further processing. Art. 122(4)
R. 136(3)
Guid. E-VIII, 2.2.4

228 Applications for re-establishment of rights must be filed in writing within two months from removal of the cause of non-compliance. The omitted act must be completed within the same period. Applications are admissible only within the year immediately following the missed time limit. Requests for re-establishment of rights in respect of any of the periods specified in Article 87(1) and in Article 112a(4) must however be filed within two months of expiry of that period.

R. 136
Guid. E-VIII, 2.2.5

The application must state the grounds on which it is based, and must set out the facts on which it relies. It is not deemed to have been filed until the fee for re-establishment of rights has been paid.

Annex I

Charts showing the procedure for the grant of a European patent

Overview of procedure

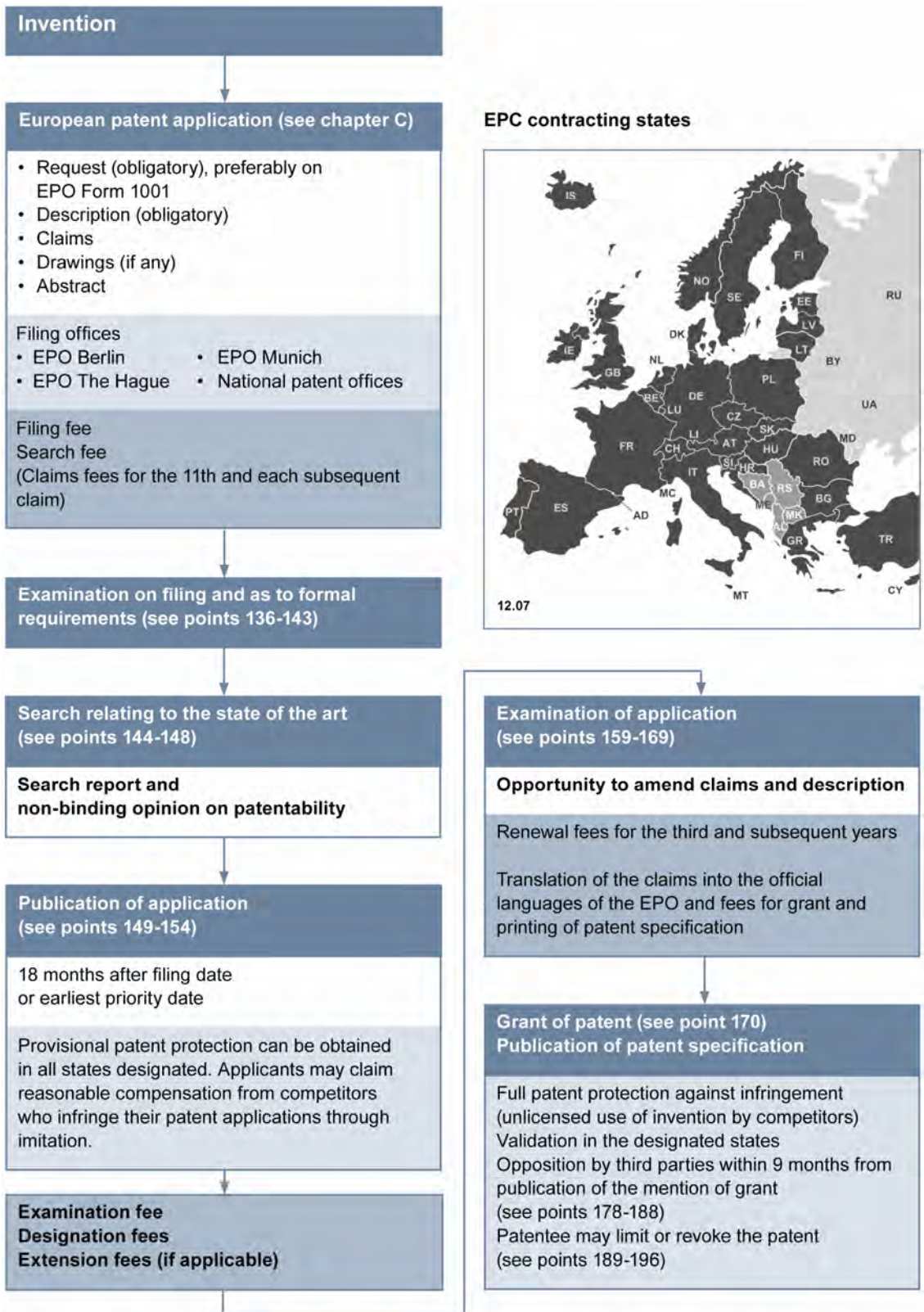

Any party adversely affected by a decision may appeal against that decision (see points 197-207).

Flowchart of the European patent grant procedure

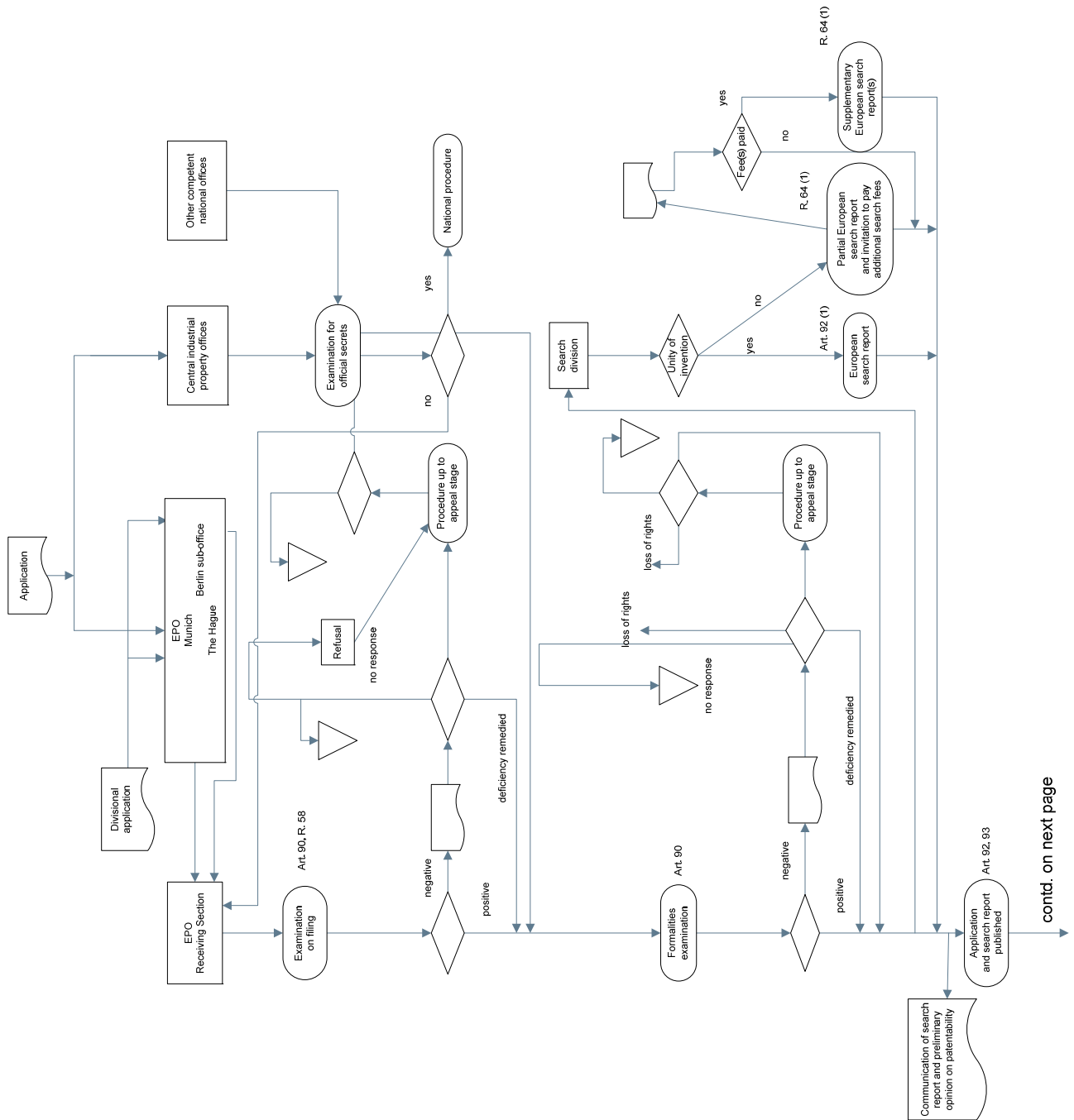
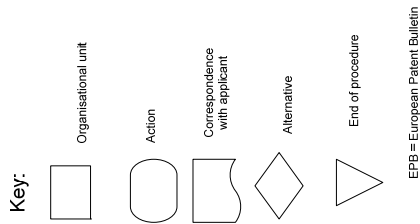

Contd. from previous page

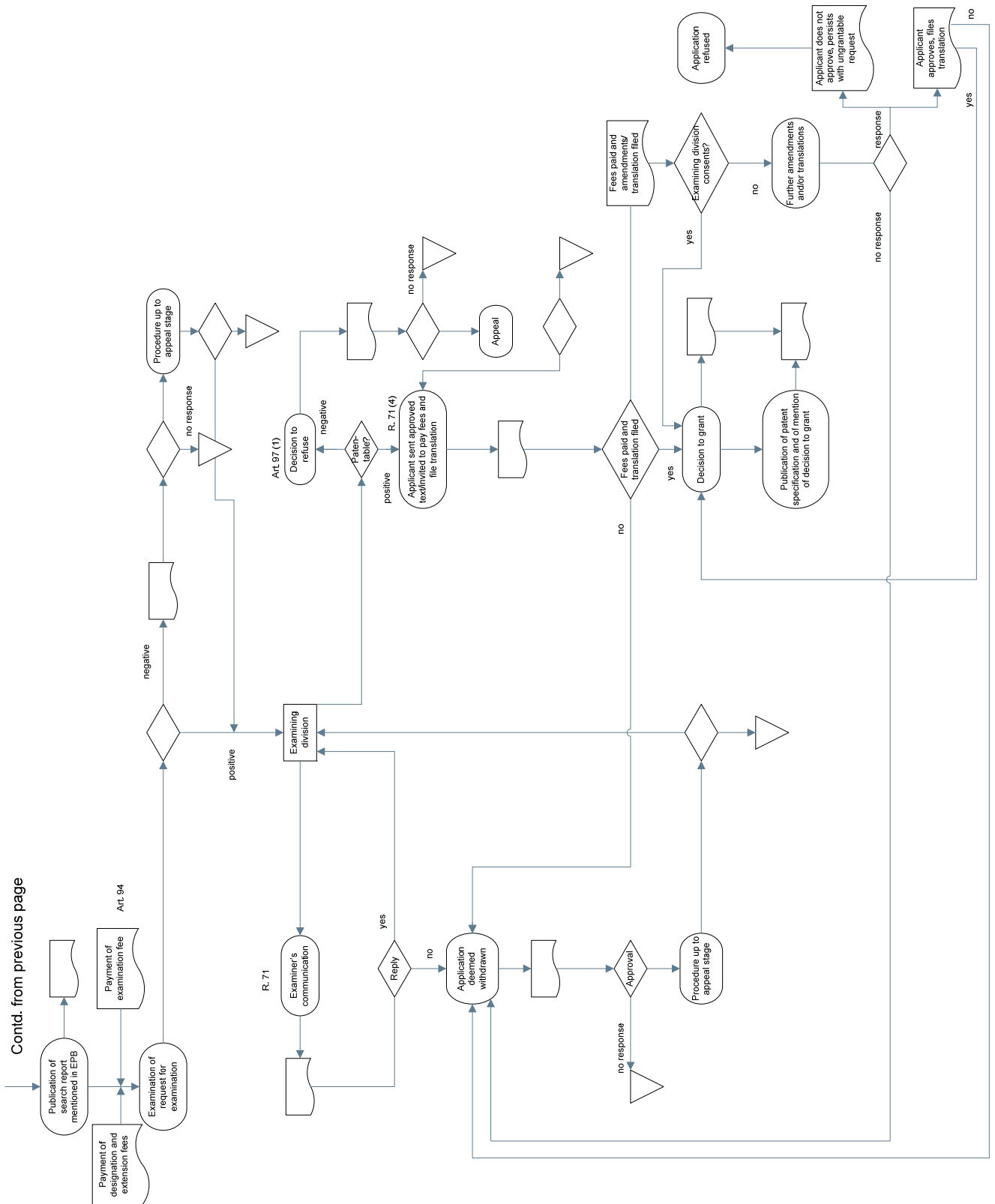

Procedures for limitation, revocation and opposition

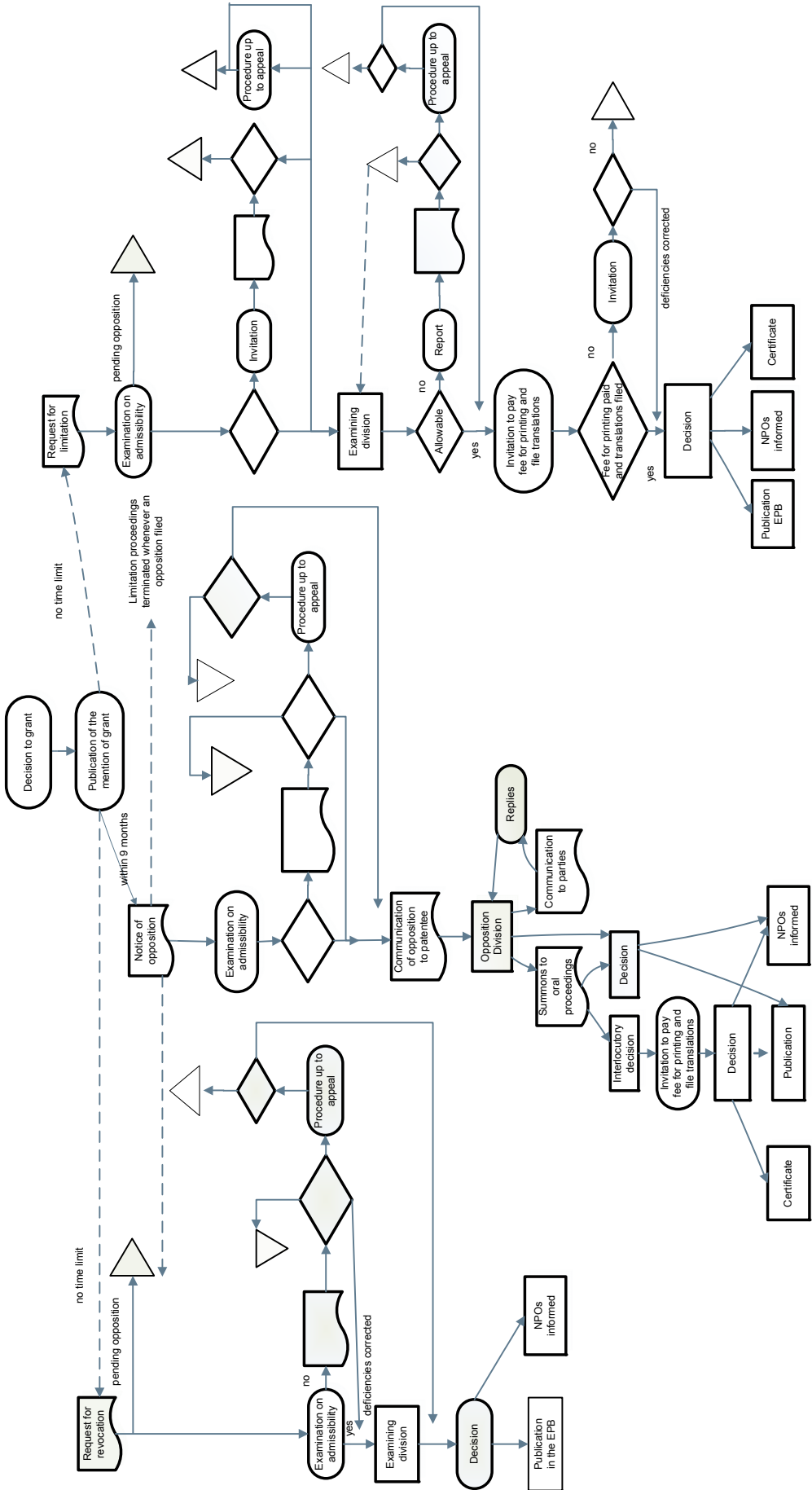

Annex II

Special edition No. 3, OJ 2007, F.1.

Notice from the European Patent Office dated 14 July 2007 concerning the programme for accelerated prosecution of European patent applications – "PACE" ¹

The entry into force of the revised European Patent Convention (EPC 2000) means updating the established PACE programme. Besides the changes to the European patent grant procedure made in the EPC 2000, the revised PACE programme also takes account of the extended European search report (EESR) introduced in 2005.

As in the past, PACE enables applicants who want their applications processed rapidly to obtain the search report, the first examination report and any communication under Rule 71(3) EPC within tight deadlines². This also applies to the opinion on patentability (under Rule 62(1) EPC) which is sent to the applicant together with the search report.

More details of the PACE programme, including any peculiarities for Euro-PCT applications, are given below.

1. Accelerated prosecution of European patent applications normally occurs on written request. The EPO does not publish requests for accelerated search and/or examination (PACE requests) and, by decision of the President dated 12 July 2007³, they are excluded from file inspection, provided they are made using EPO Form 1005⁴ or on a separate sheet of paper.

Search

2. For European patent applications claiming **no priority (first filings)**⁵, the Office always performs an accelerated search; no separate request is needed. In such cases, the Office ensures that as a rule applicants obtain their search reports **within six months** of the filing date.
3. For European patent applications which do claim priority (**second filings**), **accelerated search** can be requested when the application is filed. In such cases, the Office makes every effort to issue the search report as soon as possible.
4. In either case, however, an accelerated search is possible only if the application documents **on filing** are complete enough for the search to be performed. That means in particular providing the Office at that time with the claims, the description, the translations required and, where applicable, the drawings and a sequence listing conforming to the rules for the standardised representation of nucleotide or amino acid sequences. In particular, prosecution under PACE is not possible if use is made of the possibility of referring to an earlier application (see Rule 40(1)(c) in conjunction with (2) EPC) or of subsequently filing parts of the description, or drawings under Rule 56 EPC, as well as where the claims are filed subsequently.

1 Revised and expanded version of the notice last published in OJ EPO 2001, 459.

2 However, this service can be provided only where practically feasible, and in certain technical fields there may be constraints due to the numbers of incoming PACE requests.

3 See Special edition No. 3, OJ EPO 2007, J.3.

4 EPA/EPO/OEB Form 1005 11.01 is obtainable free of charge from the EPO (**preferably from Vienna**, but also from Munich, The Hague and Berlin) and the central industrial property offices of the member states. It is also available from the EPO website at <http://www.epo.org>

5 The Office treats European patent applications as "first filings" only if the applicant indicates on filing that he is not claiming priority.

Examination

5. **Accelerated examination** can be requested in writing when filing the European patent application, provided examination is bindingly requested⁶ at the same time, in response to the search report, or subsequently.

For Euro-PCT applications, it can be requested on or after entry into the European phase before the EPO⁷. If requested on entry, accelerated prosecution covers formalities examination⁸, drawing up the supplementary European search report, and substantive examination.

6. When accelerated examination is requested, the Office makes every effort to issue the **first examination communication within three months** of receipt by the examining division of the application or the request for accelerated examination (whichever is later).

The Office aims to produce all subsequent examination communications within three months of receipt of the applicant's reply, provided this is received within the time limit set by the examining division in its previous communication and deals with all the points raised.

Accelerated examination can be carried out efficiently only if the applicant cooperates with the Office.

Other ways of accelerating the European grant procedure

7. Before the applicant receives the search report, he can waive the invitation under Rule 70(2) EPC and request examination unconditionally, irrespective of the result of the search. In this case, under Rule 62 EPC the European search report is issued together with a first examining communication instead of the opinion on patentability. A prompt and full response from the applicant then ensures that the proceedings can continue quickly.
8. The applicant may file a substantive response to the search report or – in the case of a Euro-PCT application entering the European phase before the EPO as designated Office – to the extended international search report, without waiting for the first examination communication. A "substantive" response means reasoned observations or appropriate amendments to the application.

6 I.e. the applicant has paid the requisite fee and unconditionally waived the invitation from the Office under Article 94 in conjunction with Rule 70(2) EPC).

7 With Euro-PCT applications, the applicant can speed up entry into the European phase by expressly requesting early processing under Articles 23(2) or 40(2) PCT. However, accelerated examination in the European phase will not be performed unless requested separately under the PACE programme.

8 This is the case if the EPO did not draw up a supplementary European search report, i.e. if it drew up the international search report or if, for international applications filed before 1 July 2005, the Austrian, Spanish or Swedish patent office did (see OJ EPO 2005, 422 and 546).

Annex III

Examples of European patent applications

This section contains three sample European patent applications (description, claims, drawings and abstract), one for each of the following technical fields:

- chemistry
- electricity/physics
- mechanics.

These examples comply with the provisions governing European patent applications. However, because of the need to include explanatory notes, the margins could not be left blank (see point 71). For the requirements governing disclosure of the invention see points 67 and 68. The content of these examples is not necessarily patentable.

Chemistry

Art. 78, 83
R. 42
Description of
invention

Method for chemical synthesis of oligonucleotides

Title of invention
(designation in
Request for Grant
suffices)

Field of the Invention

The present invention relates to a method for
chemical synthesis of oligonucleotides. In
particular, the present invention relates to a
novel method capable of chemically synthesizing
5 a long-chain DNA or RNA fragment easily and
reliably from a base moiety-unprotected
nucleotide phosphoroamidite as a unit, as well
as to a novel compound used in said method.

R. 42(1)(a)
Technical field to
which invention
relates

10 Background of the Invention

The phosphoroamidite method is used most widely
at present as a method of chemically synthesizing
oligonucleotides such as DNA fragments and RNA
15 fragments (Nucleic Acids Research, 17:7059-7071,
1989). In general, this phosphoroamidite method
makes use of a condensation reaction between a
nucleoside phosphoroamidite and a nucleoside as
a key reaction using tetrazole as an
20 accelerator. Because this reaction usually
occurs competitively on both the hydroxyl group
in a sugar moiety and the amino group in a
nucleoside base moiety, the selective reaction
on only the hydroxyl group in a sugar moiety is
25 required to synthesize a desired nucleotide.
Accordingly, the side reaction on the amino
group was prevented in the prior art by
protecting the amino group, as illustrated in
the following reaction scheme:

R. 42(1)(b)
Relevant prior art

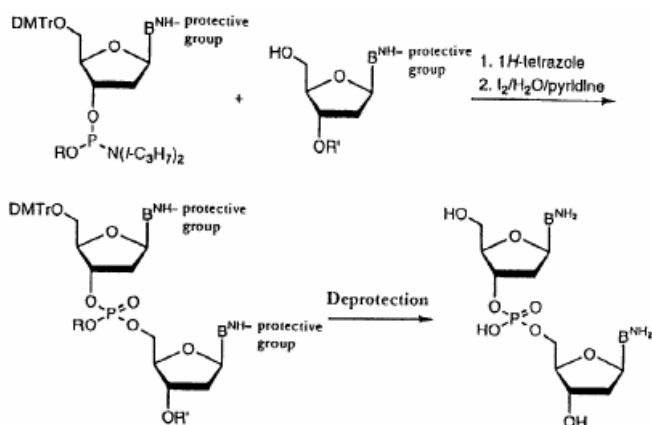

5 However, the protective group should be removed when synthesis was finished, and operationally complicated organic reactions and a large amount of expensive and harmful reagents are required to introduce and remove said protective group, which in view of practical usability, economical efficiency, environmental protection etc., is a great problem in carrying out this prior method. Accordingly, there is demand for a method of chemically synthesizing an oligonucleotide from an amino group-unprotected nucleoside phosphoroamidite as a unit, and the method of Letsinger et al., as shown in the following reaction scheme, is known as a pioneering method (Nucleic Acids Research, 20:1879-1882, 1992):

Assessment of prior art

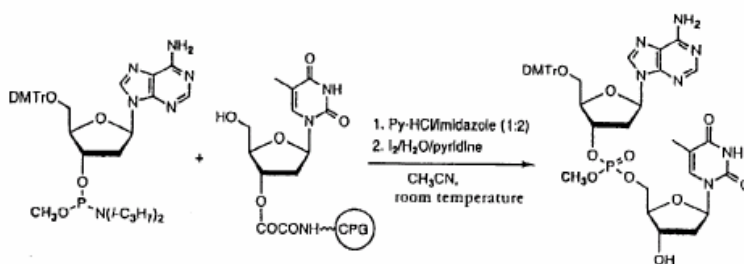

20 However, the method of Letsinger et al. is not practical, not universal and is not used in practice since there are following disadvantages:

25 (1) condensation yield in each step is low (about 97%: at least 99% yield is required for synthesis of a 50-mer or more long-

chain oligonucleotide) and a commercial automatic DNA synthesizer cannot be used for this method, so a long-chain oligonucleotide consisting of 50 to 100 nucleotides generally required in chemical synthesis of DNA etc. cannot be synthesized;

(2) highly reactive, specific nucleoside phosphoroamidites only can be used, and thus this method has a limited scope of application and is not practical; and

(3) pyridine hydrochloride used as an accelerator is an unstable compound with very high moistureproofness, and thus its handling is difficult.

Summary of the Invention

The present invention was made in view of the prior art described above, and the object of the present invention is to provide a practical method capable of chemically synthesizing a 100-mer or more long-chain oligonucleotide easily and reliably as well as a novel compound used in said method.

*R. 42
Technical Problem*

To solve the problem, the present invention provides a method for chemical synthesis of an oligonucleotide by the phosphoroamidite method, which comprises preparing a base moiety-unprotected nucleoside phosphoroamidite from a base moiety-unprotected nucleoside by use of an imidazole trifluoromethanesulfonate represented by the following chemical formula, and coupling said base moiety-unprotected nucleotide phosphoroamidite in a predetermined order in the presence of said imidazole trifluoromethanesulfonate to chemically synthesize an oligonucleotide consisting of a specific nucleotide sequence.

*R. 42(1)(c)
Disclosure of
invention
R. 42(1)(c)
Advantageous
effects of invention*

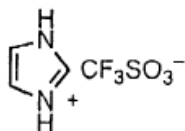

In a preferable embodiment of the method of this invention, the coupled, base moiety-unprotected
5 nucleoside phosphoroamidite is treated with a benzimidazole trifluoromethanesulfonate solution.

That is, the present inventors found that a base moiety-unprotected nucleoside phosphoroamidite
10 prepared by use of the compound, imidazole trifluoromethanesulfonate (referred to hereinafter as imidazolium triflate) in place of the conventionally used tetrazole as an accelerator for condensation reaction between
15 nucleoside phosphoroamidite and nucleotide is free of the side reaction on the amino group in the nucleotide base moiety thereof, and as a result, they found that complicated procedures such as, for example, introduction and removal
20 of a protective group are not required, and also that its synthesis can be conducted by a commercial synthesizer, thereby completing this invention. Further, the present inventors found that the side reaction on the amino group in the
25 base moiety can be completely inhibited by treating the above-described coupled, base moiety-unprotected nucleoside phosphoroamidite with a methanol solution of a benzimidazole trifluoromethanesulfonate (referred to
30 hereinafter as benzimidazolium triflate) whereby a more perfect oligonucleotide is synthesized, and the present invention was thereby completed.

Advantageous effects of invention

Brief Description of the Drawings

5 Fig. 1 is a schematic drawing of each reaction step in the method of this invention.

*R. 42(1)(d)
Brief description of drawings*

Fig. 2 is a schematic drawing of each reaction step in the method of the present invention where ammonia treatment was performed.

10 Fig. 3 is a HPLC profile of DNA fragments synthesized in the method of this invention.

Detailed Description of the Invention

15 Hereinafter, the best mode for carrying out the present invention is described in detail.

*R. 42(1)(e)
Description of at least one way of carrying out the invention with reference to drawings*

20 The imidazolium triflate of the present invention can be prepared by mixing imidazole with trifluoromethanesulfonic acid in 1 : 1 equivalents in dichloromethane, as illustrated below in its preparation example in Example 1.

25 The imidazolium triflate thus obtained does not absorb moisture as also shown in Example 1 and is extremely stable under usual conditions for use, so it can be easily handled.

30 In the chemical synthetic method of this invention, a base moiety-unprotected nucleoside phosphoroamidite is prepared from a base moiety-unprotected nucleotide by use of the imidazolium triflate as described above, and this base
35 moiety-unprotected nucleoside phosphoroamidite is used as a unit and each nucleoside phosphoroamidite is coupled in a predetermined order thereby chemically synthesizing an
40 nucleotide sequence.

The base moiety-unprotected nucleoside phosphoroamidite can be prepared by reacting the base moiety-unprotected nucleoside phosphoroamidite with cyanoethyl-bis-amidite in the presence of the imidazolium triflate as a catalyst as illustrated e.g. in Example 2 below. In this case, the reaction occurs selectively on the hydroxide group in the sugar moiety of the nucleoside, so four kinds of N-unprotected nucleoside phosphoroamidites used in DNA synthesis, that is, deoxyadenosine, deoxythymidine, deoxyguanosine and thymidine phosphoroamidites can be obtained quantitatively.

The four kinds of N-unprotected nucleoside phosphoroamidites thus obtained are used as units to synthesize an oligonucleotide consisting of a desired nucleotide sequence by the solid-phase synthetic method etc. known in the art. Further, this synthetic reaction can also be conducted in a commercial DNA synthesizer by a method according to its protocol.

In the method of this invention, each coupled N-unprotected nucleoside phosphoroamidite is preferably subjected after each coupling to treatment with a solution (e.g. an ethanol solution) of benzimidazolium triflate. By this treatment, the side reaction on the amino group in the base moiety is completely inhibited, and a more perfect oligonucleotide is thus synthesized.

The benzimidazolium triflate can be synthesized in the following reaction scheme:

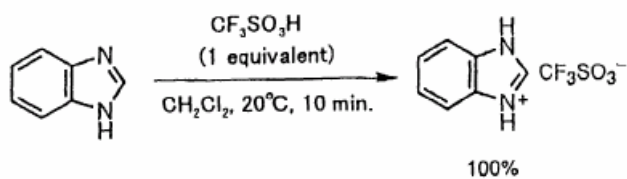

Examples

Hereinafter, the present invention is described
10 in more detail and specifically with reference
to the Examples, which however are not intended
to limit the present invention.

Example 1: Preparation of imidazolium triflate

15

Imidazole and trifluoromethanesulfonic acid were
mixed in 1 : 1 equivalents in dichloromethane
and reacted at 25° C for 10 minutes as shown in
the reaction scheme below, whereby the
20 imidazolium triflate of this invention was
prepared.

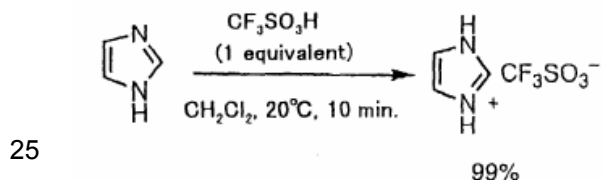

As a result of analysis in conventional methods,
the resulting imidazolium triflate had the
30 characteristics shown in Table 1.

Table 1

35

Colorless crystal
Melting point: 197-198 °C
Elementary analysis
Theoretical: C ₄ H ₅ F ₃ N ₂ O ₃ S: C, 22.02; H, 2.31; N, 12.84
Found: C, 21.96; H, 2.30; N, 12.74
No moistureproofness

Example 2: Preparation of base moiety-
unprotected nucleoside phosphoroamidite

The imidazolium triflate obtained in Example 1
was used as the catalyst so that a base moiety-
5 unprotected nucleoside was reacted with
cyanoethyl-bis-amidite, as shown in the
following reaction scheme:

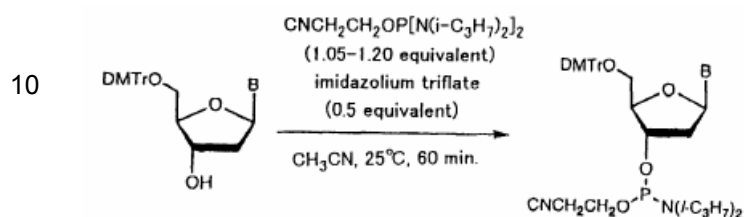

15 By this reaction, the four kinds of N-
unprotected nucleoside phosphoroamidites shown
in Table 2, that is, deoxyadenosine,
deoxythymidine, deoxyguanosine and thymidine
phosphoroamidites were prepared respectively. As
20 also shown in Table 2, the respective nucleoside
phosphoroamidites were obtained almost
quantitatively.

Table 2

25

B:				
yield, %:	96	98	97	99
purity, %:	>98	>98	>96	>99
³¹ P NMR, ppm:	149.0, 149.1	149.2, 149.3	149.1, 149.2	149.0, 149.1

30

Example 3: Synthesis of DNA fragment

From the 4 kinds of N-unprotected nucleoside
35 phosphoroamidites as units obtained in
Example 2, a 60-mer DNA fragment consisting of
the nucleotide sequence of SEQ ID NO: 1 was
synthesized by the solid-phase synthetic method
using a commercial DNA synthesizer. The reaction
40 cycle was as shown in Table 3.

Table 3

Step	Operation	reagents(s)	time, min
1	washing	CH ₃ CN	0.50
2	ditritylation	3 % CCl ₃ COOH/CH ₂ CH ₂	1.0×3
3	washing	CH ₃ CN	2.0
4	coupling	0.1 M amidite/CH ₃ CN + 0.1 M IMT/CH ₃ CN	0.25
5	wait		1.0
6	N-P cleavage	0.3 M BIT/CH ₃ CN	0.50
7	wait		2.0
8	washing	CH ₃ CN	0.50
9	oxidation	1 M t-C ₄ H ₉ OOH/CH ₂ Cl ₂	0.25
10	wait		1.0

BIT = benzimidazolium triflate; IMT = imidazolium triflate

5

10 In this synthetic reaction, each step
(condensation reaction) in the chain-elongation
shown in Table 1 proceeded in almost 100% yield,
and a phosphate moiety-protected 60-mer
oligonucleotide was obtained usually in 100%
15 yield. This yield was extremely high in
considering that the yield of a 60-mer
oligonucleotide by generally conducted
conventional methods is about 20 to 40%.

20 Further, as shown in Fig. 2, deprotection and
elimination by treatment with an ammonia
solution (25° C, 60 minutes) were carried out
whereby the unprotected 60-mer DNA was obtained
in quantitative yield.

25

Analysis of the resulting crude unprotected 60-
mer DNA by high performance liquid
chromatography under the conditions shown in
Table 4 indicated that its purity was 95% or
30 more as shown in Fig. 3.

Table 4

Analytical conditions	
Column	DEAE-2.5 μ (250 mm)
Flow rate	0.5 mL/min
Temperature	25 °C
Eluent: A	20 mM Tris-HCl (pH 9.0)
B	A + 1 M NaCl
Gradient	A : B (100 : 0) → (50 : 50) linear gradient

35

As described above in detail, the method of
synthesizing oligonucleotides by use of this
40 imidazolium triflate have the following
advantages:

70

(1) condensation yield in each step is as high as 100%, and the present method can also be applied to an automatic synthesizer by merely changing a program for synthesis and reagents used, so synthesis of a long-chain oligonucleotide consisting of 50 to 100 nucleotides generally required in chemical synthesis of DNA etc. is feasible in 1/10 or less costs as compared with those of conventional methods;

(2) because unspecified nucleotide phosphoroamidites can be used, the present method has a broad scope of application and is practical; and

(3) the imidazolium triflate of this invention used as an accelerator is a stable compound which does not absorb moisture, so its handling under usual conditions for use is very easy.

SEQUENCE LISTING

SEQ ID NO: 1

LENGTH: 60 bases

25 TYPE: nucleic acid

STRANDEDNESS: single

TOPOLOGY: linear

MOLECULAR TYPE: synthetic DNA

SEQUENCE:

30

TATGGGCCTT TTGATAGGAT GCTCACCGAG CAAAACCAAG AACCAACCAGG AGATTTTATT 60

Claims

1. A method for chemical synthesis of an
oligonucleotide by the phosphoroamidite
5 method, which comprises preparing a base
moiety-unprotected nucleoside
phosphoroamidite from a base moiety-
unprotected nucleoside by use of an
imidazole trifluoromethanesulfonate
10 represented by the following chemical
formula, and coupling said base moiety-
unprotected nucleotide phosphoroamidite in
a predetermined order in the presence of
imidazole trifluoromethanesulfonate to
15 chemically synthesize an oligonucleotide
consisting of a specific nucleotide
sequence.

20

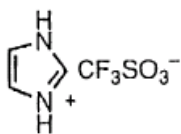

25

2. A method according to claim 1, wherein the
coupled base moiety-unprotected nucleoside
phosphoroamidite is treated with a
benzimidazole trifluoromethanesulfonate
solution.

R. 43(1)(a)
Independent claim

R. 43(3), (4)
Dependent claim

Abstract

Art. 85

Method for chemical synthesis of oligonucleotides

R. 47(1)

Title of invention

The present invention provides a practical method capable of chemically synthesizing a 100-mer or more long-chain oligonucleotide easily and reliably and a novel compound used in said method. The present invention relates to a method for chemical synthesis of an oligonucleotide by the phosphoroamidite method, which comprises preparing a base moiety-unprotected nucleoside phosphoroamidite from a base moiety-unprotected nucleoside by use of an imidazole trifluoromethanesulfonate represented by the following chemical formula, and coupling said base moiety-unprotected nucleotide phosphoroamidite in a predetermined order to chemically synthesize an oligonucleotide consisting of a specific nucleotide sequence, as well as to an imidazole trifluoromethanesulfonate represented by the chemical formula.

R. 47(2), (3), (5)

Content of abstract

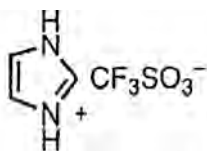

Fig. 1

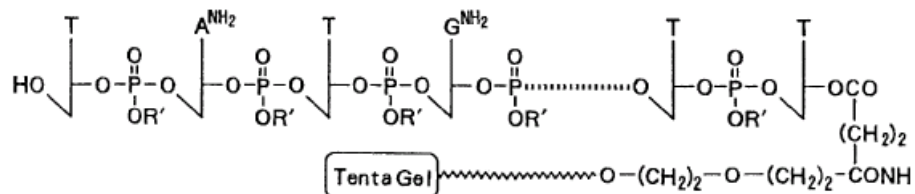

Fig. 2

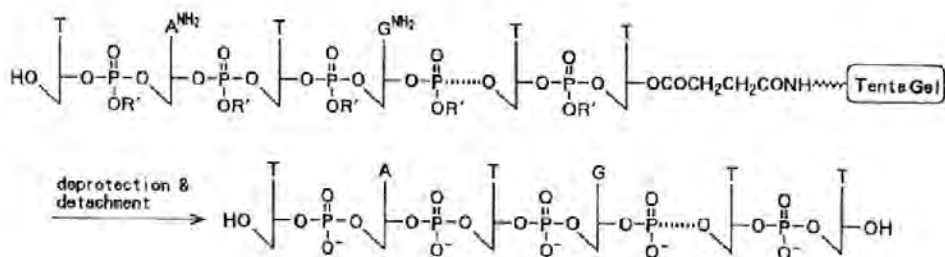
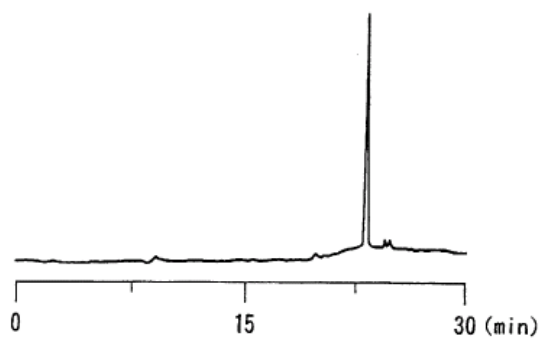

Fig. 3



Electricity/physics

Art. 78, 83
R. 42
*Description of
invention*

Foldable electronic device

*Title of invention
(designation in
Request for Grant
suffices)*

The present invention relates to an electronic device, such as a mobile communications device.

*R. 42(1)(a)
Technical field to
which invention
relates*

Mobile telephones and similar communication
5 devices are rapidly expanding in use and
function. Such devices will soon provide
Internet access, personal information
management, facsimile, messaging, in addition to
telephone communication. To accomplish this
10 there is a need to provide keyboards compatible
with the more complex applications to which the
mobile device will be adapted. Full function
keyboards, such as the standard QWERTY typing
array of keys and buttons, are difficult to
15 provide while maintaining the compact size
required in the mobile device. Such devices on
the market today are cumbersome and often
require a separate belt pouch for carrying the
mobile device on the person of the user. In
20 addition it is necessary to coordinate on screen
displays for adaptation to the variety of
functions.

*R. 42(1)(b)
Indication of the
background art*

EP-A-0933908 describes a mobile communications
25 device having a body portion and a lid hingably
coupled to the body portion. A key is provided on
a surface of the body portion which is covered
by the lid when the lid is closed. A key is also
provided on an inner surface of the lid. When
30 the lid is open, the keys on the body portion
and on the lid provide a keyboard.

*R. 42(1)(b)
Specific documents
reflecting
background art*

The present invention seeks to provide an improved electronic device.

*R. 42(1)(c)
Technical problem to
be solved*

According to the present invention there is provided an electronic device for operation in multiple application comprising a body element having upper and lower faces relative to usage,
5 a screen constructed in an upper face of the body element to provide a visible display of information to the user, a first panel fixed to the upper face of the body element, a second panel mounted on the body element for pivotal
10 motion thereon between open and closed positions, the second panel having first and second faces, the first face accessible to the user in the closed position and the second face accessible to the user in the open position and
15 a functional keyboard constructed in two portions, a first portion constructed in the second face of the second panel and a second portion constructed in the first panel, each of the functional keyboard portions having an array
20 of keys consistent with a selected function, when the function keyboard is exposed for operative use in the function position and wherein the first and second functional keyboard portions are on opposite sides of the screen in
25 the open position.

The first and second panels may be in overlapping alignment in the closed position and on opposite sides of the opposite screen in the
30 open position. The function keyboard may comprise a full function QWERTY key array split in first and second portions constructed respectively in first and second panels. The function keyboard may comprise a game controller
35 with multiple functions keys divided between the first and second panels. The array of keys on the faces of the panels may be offset to prevent interference between the keys of the faces in the closed position. The device may be a mobile
40 communication device and further comprise a

communication keypad constructed on the first
face of the second panel, the keypad being
exposed for operative use in the closed
position. The device may further include a
5 control unit, the control unit operating to
control the orientation display of the screen
consistent with the functional position of the
first and second panel that is aligned with the
communication keypad in the closed position and
10 aligned with the functional keyboard in the open
position. The display on the screen may be
rotated 90° between the open and closed
positions. The orientations may be controlled by
the position of the second panel. The
15 communication device keypad may be locked in an
inoperative mode in the open position.

Embodiments of the present invention with now be
described, by way of example, with reference to
20 the accompanying drawings in which:

R. 42(1)(d)
Brief description of
drawings

Figure 1 is a top view of an embodiment of
a communications device according to the
present invention in a closed position;
25

Figure 2 is a top view of an embodiment of
a communications device according to the
present invention in an open position;

30 Figure 3a is a side view of an embodiment
of a communications device according to
the present invention in a closed
position;

35 Figure 3b is a schematic illustration of a
display orientation when the
communications device shown in Figure 3a
is in a closed position;

40 Figure 3c is a schematic illustration of
the display orientation when the

communication device shown in Figure 3a is in the open position;

5 Figure 4 is a block diagram of the control system of an embodiment of a communication device according to the present invention; and

10 Figure 5 is a top view of an alternative embodiment of this invention.

A mobile communication device is provided with a full function keyboard. For the purpose of illustration, this invention will be described with reference to a mobile telephone, but is applicable to other devices such as pagers, game units and the like. As shown in figure 3a, a mobile telephone 1 is constructed having a body 2. The body 2 encloses a screen 3 which provides a display 4 for communicating pertinent information to the user in response to actions by the user. The mobile telephone 1 is constructed having two panels 5 and 6 which are mounted on the body 2. In figure 3, panel 5 is shown fixed to body 2 as a separated component, but it could also be constructed integrally with body 2. Panel 6 is rotatable on the body 2 about an axis x-x as shown in figures 1 and 2.

30 In a first position, referred to as the closed position, panel 6 is rotated into overlapping alignment with panel 5, as shown in figure 3a. Rotating panel 6 has two opposing flat faces 7 and 8. Face 7 is the inner face when panel 6 is in the closed position and face 8 is the outer face in the closed position. In the preferred embodiment, face 8 contains a standard telephone keypad 9 for use when the mobile phone 1 is operating strictly in the communication mode. In the closed position, the device operates as a standard operating mobile telephone with the

*R. 42(1)(e)
Description of at
least one way of
carrying out the
invention*

display 4 of screen 3 oriented in alignment with keypad 9.

To provide the full function keyboard of the preferred embodiment of this invention, the key and button array 12, used for the particular application, is divided in half and arranged on left and right keyboard portions 10 and 11, on opposite sides of the screen (3) in the open position. To facilitate operation of the keyboard, it is designed for thumb actuation by both hands. This makes it convenient to hold the small device in both hands and operate the keyboard portions 10 and 11 accurately and efficiently.

As shown best in figure 3, the left hand keyboard portion 10 is constructed on face 7 of rotating panel 6 on the opposite side of telephone keypad 9. The right hand keyboard portion 11 is constructed on upper face 13 of panel 5. A back cover is assembled on the face 14 of panel 5. To insure a compact engagement of panels 5 and 6 in the closed position, the portions of key array 12 on the opposing panel faces 7 and 13 are offset to avoid interference in the closed position.

To operate the keyboard array 12, panel 6 is rotated approximately 180° to the open position to form a substantially flat unit having right and left keyboard portions separated by screen 3 as shown in figure 2. By holding the left and right hand portions in either hand, the keyboard, thus extended, can be conveniently operated using thumbs. In the open position, outer face 8 of panel 6 is oriented away from the user.

The display 4 of screen 3 is controlled for orientation in two positions depending on the

mode of use. In the closed position, the display 4 is oriented in alignment with the keypad 9, while in the open position the display 4 is aligned with the function key array 12. As shown
5 in figures 3b and 3c, display orientation is rotated 90° between the mobile telephone mode in which panel 6 is in the closed position to the full function mode when panel 6 is in the open position. This is accomplished by providing a
10 panel position indicator 15 which signals control unit 16 when the panel 6 is opened or closed. Control unit 16 may be a microprocessor, display driver or other means including hardware or software. This could be automatic or by a
15 manual button operated by the user. The control-unit 16 will signal the display control 17 to orient the position of the display as needed. In addition, in the open position, keypad 9 will be locked in an inoperative mode by telephone
20 keypad lock 18.

In an alternate embodiment shown in figure 5, instead of a keyboard, a game controller keypad is provided. The game keyboard consists of
25 action buttons 19 and motion pad 20 constructed in panels 5 and 6 respectively. The telephone keypad 9 is constructed in the reverse side of panel 6, as described above. As a further alternative, the device could be designed
30 without a communication capability and used as a game unit only.

In this manner, a simple and compact keyboard is provided in operative association with a mobile
35 communications device. It should be noted that other key arrays can be used such as the French AZERTY or the German QWERTZ(U). The device would also be useful as a microprocessor based game unit driven by game software or firmware.

Claims

Art. 84
R. 43

1. An electronic device for operation in multiple applications comprising:

R. 43(1)(a)
Prior art portion of independent claim wherever appropriate

5 a body element (2) having upper and lower faces (13,14), relative to usage;

a screen (3) constructed in the upper face (13) of said body element to provide a
10 visible display (14) of information to the user;

a first panel (5) fixed to the upper face (13) of said body element;

15 a second panel (6) mounted on the body element for pivotal motion thereon between open and closed positions, said second panel (6) having first and second faces
20 (7,8); said first face (8) accessible to the user in said closed position and said second face (7) accessible to the user in said open position; and

25 a function keyboard constructed in two portions (10,11), a first portion (10) constructed in the second face (7) of said second panel (6) and a second portion (11) constructed in said first panel (5), each
30 of said function keyboard portions having an array (12) of keys consistent with a selected function, wherein said function keyboard is exposed for operative use in the open position, **characterised in that**
35 said first and second functional keyboard portions (10,11) are on opposite sides of said screen (3) in the open position.

R. 43(1)(b)
Characterising portion

R. 43(3), (4)
Dependent claim

2. An electronic device according to claim 1,
wherein said first and second panels (5,6)
are in overlapping alignment in the closed
position and wherein said first and second
5 panels are on opposite sides of said screen
(3) in the open position.
3. An electronic device according to claim 1
or 2, wherein said function keyboard
10 comprises a full function QWERTY key array
split in first and second portions (10,11)
constructed respectively in said first and
second panels (5,6).
- 15 4. An electronic device according to any
preceding claim, wherein said function
keyboard comprises a game controller with
multiple functions keys (19,20) divided
between said first and second panels (5,6).
- 20 5. An electronic device according to any
preceding claim, wherein said array (12) of
keys on said faces of said panels (5,6) are
offset to prevent interference between the
25 keys of said faces in the closed position.
6. An electronic device according to any
preceding claim, wherein said device is
mobile communication device and further
30 comprises a communication keypad (9)
constructed on said first face (8) of said
second panel (6), said keypad being exposed
for operative use in the closed position.
- 35 7. An electronic device according to claim 6,
further including a control unit (16), said
control unit operating to rotate the
orientation of the display (4) on the
screen (3) consistent with the functional
40 position of the first and second panels
(5,6) so that it is aligned with said

communication keypad (9) in the closed position and aligned with said functional keyboard (10,11) in said open position.

- 5 8. An electronic device according to claim 7, wherein the display (4) on the screen (3) is rotated 90° between said open and closed positions.
- 10 9. An electronic device according to claim 7 or 8, wherein said orientation is controlled by the position of the second panel (6).
- 15 10. An electronic device according to any one of claims 6 to 9, wherein the communication device keypad (9) is locked in an inoperative mode in the open position.

Abstract

Art. 85

Foldable electronic device

R. 47(1)
Title of invention

A full function keyboard is provided for use with a mobile communication device. The keyboard is constructed in two portions (10, 11) which may be pivoted relative to the body of the device between two positions, one in which the keyboard is hidden and the keypad of the device is exposed for normal use and a second in which the two portions of the keyboard are positioned on opposite sides of the screen of the device to allow holding with both hands and operation with the thumb.

R. 47(2), (3), (5)
Content of abstract

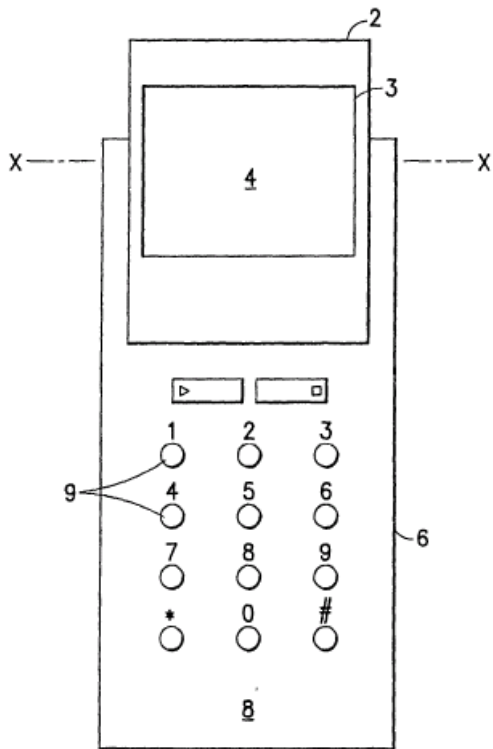

FIG. 1

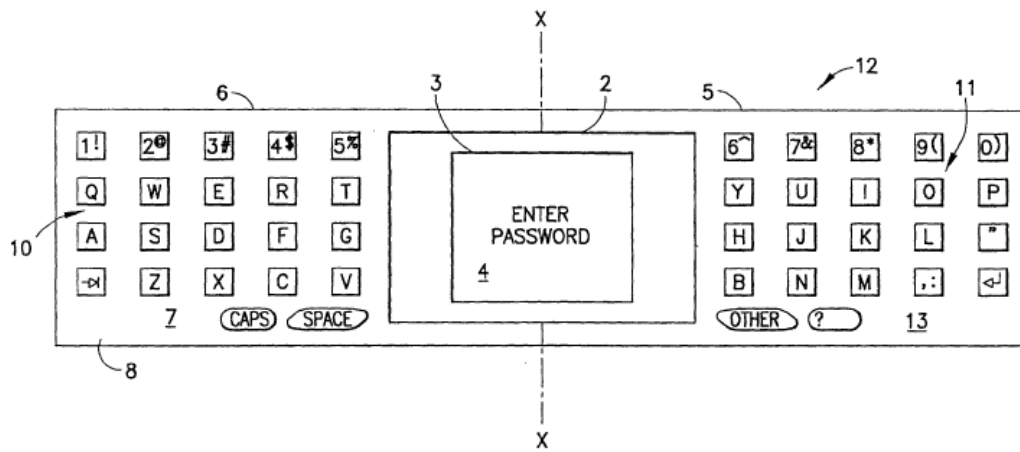

FIG. 2

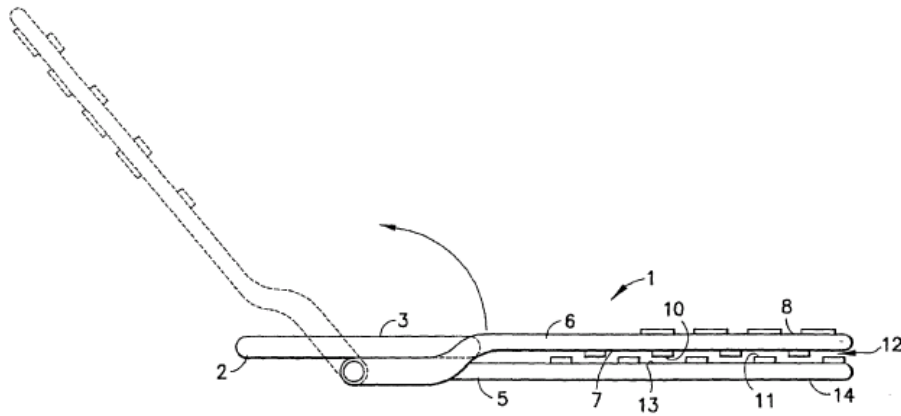

FIG. 3a

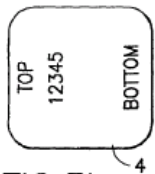

FIG. 3b

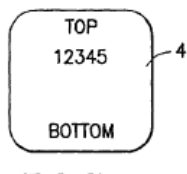

FIG. 3c

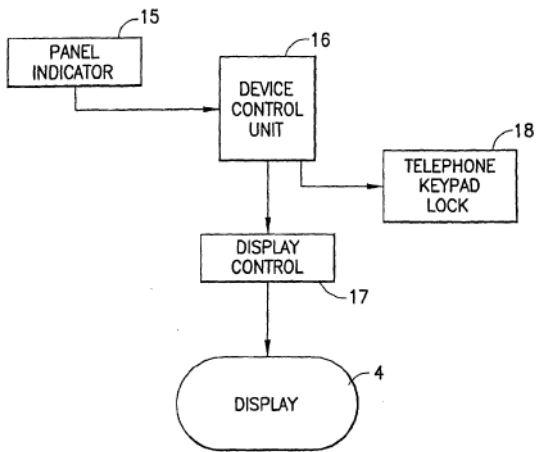

FIG. 4

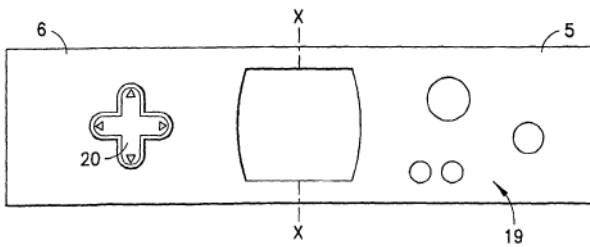

FIG. 5

Mechanics

Art. 78, 83
R. 42
*Description of
invention*

Device to deliver and mix water

*Title of invention
(designation in
Request for Grant
suffices)*

Field of the Invention

*R. 42(1)(a)
Technical field to
which invention
relates*

The invention concerns a device for to deliver
and mix water able to be employed in

5 electronically controlled taps wherein delivery
is commanded, substantially automatically,
through sensor means which detect the presence
of the user.

10 Background of the Invention

*R. 42(1)(b)
Indication of the
background art*

The state of the art includes monocommand mixer
taps comprising a mixer cartridge, located
inside the monoblock of the tap, associated with
15 a lever, which allows to regulate both the
mixing and the delivery of the water, and which
is mounted above the monoblock.

20 The state of the art also includes taps of the
electronic type wherein the water is delivered
substantially automatically when the user
approaches the taps.

25 Such taps comprise a valve provided with
interception means cooperating with a solenoid
device, or with an electric motor, able to
command the opening and closing thereof,
respectively to deliver and interrupt the flow
of water; the solenoid device or the motor is
30 activated by appropriate sensor means able to
detect the presence of the user.

In some embodiments, the valve is associated
with manual activation means which allow to
35 regulate the mix of hot and cold water.

The structure of this type of valve and the need to feed the solenoid device or drive motor of the interception means electrically make it necessary to locate the valve and the electric
5 and electronic components in the lower part of the monoblock, or cast block, of the tap, which therefore must be appropriately sized.

This means that it is necessary to design and
10 make specific monoblocks for the electronically controlled taps, that is, different from those for monocommand mixer taps, with greater problems in terms of planning the production and managing stocks.

15 Moreover, the greater size of the monoblock considerably limits the design and aesthetics of the tap.

20 Furthermore, the presence of electric and electronic parts inside the monoblock in the zone where the water passes can cause malfunctions of the tap and can compromise the safety of the user.

25 WO-A-97/47828 discloses a sanitary fitting having a housing part and an exit part containing the exit channel. A mixer tap is positioned in the housing part for mixing cold and warm fluid and
30 for controlling the flow rate. The mixer tap is actuatable between a closed final position and an opened final position by a control rod connected to an actuating lever. An electrically controllable valve is disposed in the mixer tap
35 and is connected to a proximity sensor by means of a control electronic circuit. Additionally such a valve can be controlled mechanically by means of the actuating lever via the control rod. In this known sanitary fitting the control
40 electronic circuit is disposed outside the mixer tap, while the electrically controllable valve

*R. 42(1)(b)
Specific documents
reflecting
background art*

and its actuator element are disposed inside the mixer tap, so that such mixer tap is not of standard type.

5 EP-A-0831260, which comprises the features of the preamble of claim 1, discloses a single-control mixing valve with temperature control having two operating states, a normal operating state and a manual operating state. In the
10 normal state, an adjusting knob is used to select the temperature and the opened/closed position is controlled by a solenoid valve in turn controlled by an external control circuit connected to an external power supply. The
15 present Applicant has devised and embodied this invention to overcome these shortcomings and to obtain further advantages.

Summary of the Invention

20 The invention is set forth and characterized in the main claim, while the dependent claims describe other characteristics of the invention.

25 The purpose of the invention is to achieve a device for the automatic delivery of water, which can be associated with a monoblock for mixer taps of a substantially standardized type, that is, of the type for monocommand mixer taps, thus
30 obviating the need to produce a specific monoblock for electronically controlled mixer taps.

*R. 42(1)(c)
Technical problem to
be solved*

35 Another purpose of the invention is to achieve a device for the automatic delivery of water which is practical, functional and compact and can be used in conditions of absolute safety for the user.

40 The device according to the invention comprises a mixer cartridge, able to be arranged inside a

*R. 42(1)(c)
Disclosure of
invention*

monoblock for mixer taps of a conventional type,
means to regulate the mixing of the water and
actuation means, commanded electrically, and
comprising an interception element cooperating
5 with said cartridge to open and close the flow
of water.

The actuation means is associated above the
mixer cartridge, in a position outside the
10 monoblock of the tap, and cooperate with a
sensor able to automatically determine the
activation of said actuation means in the
presence of the user.

15 The actuation means are fed by batteries.

The means to regulate the mixing, the actuation
means and the electric and electronic components
connected thereto are integrated into a single
20 block and coupled above the mixer cartridge in a
position outside the monoblock.

The device according to the invention is
therefore able to be associated with monoblocks
25 for monocommand mixer taps and thus allows to
obviate both the problem of stylistic
limitations and design imposed by the devices
for electronically controlled taps, and also the
problem of production and storage of different
30 types of monoblock.

The separation of the electric and electronic
parts from the mixer cartridge confers
characteristics of extreme safety and
35 functionality on the device according to the
invention.

Brief description of the drawings

*R. 42(1)(d)
Brief description of
drawings*

These and other characteristics of the invention will be clear from the following description of a preferential form of embodiment, given as a non-restrictive example, with reference to the attached drawings wherein:

Fig. 1 shows a longitudinal section of a device according to the invention associated with the monoblock of a tap;

Fig. 2 is a side view of a tap provided with the device according to the invention.

Detailed description of a preferential embodiment

*R. 42(1)(e)
Description of at
least one way of
carrying out the
invention*

With reference to the attached drawings, a device 10 to deliver and mix water according to the invention is able to be associated with the monoblock 11 of taps 12 of a substantially standardized type.

The device 10 comprises a mixer cartridge 30 associated at the upper part with a command and regulation unit 40.

The mixer cartridge 30 is able to be housed in the upper part of the monoblock 11 and comprises a containing body 13 closed at the bottom part by a bottom 14 of a substantially conventional type and defining therewith a compartment 15 which houses: a fixed platelet 16, a movable platelet 17, and a drawing and distribution element 18.

The bottom 14 can be associated with the monoblock 11 in correspondence with a supporting plane 22 and is provided with holes able to allow the passage of the hot and cold water

arriving from the pipes of the water system and with an aperture 14a able to allow the mixed water to flow towards the delivery outlet 21 of the tap 12.

5

The fixed platelet 16 is able to be solidly associated with the bottom 14 and has feed holes functionally connected to the hot and cold water holes of the bottom 14 and a hole 16a

10 communicating with the aperture 14a.

The movable platelet 17 is mounted rotary on a plane parallel to and above that of the fixed platelet 16; it is provided with a hole 17a able to cooperate with the hole 16a and with a curved eyelet 17b able to communicate selectively with only one or both the feed holes of the fixed platelet 16.

15

20 The drawing and distribution element 18 is associated, due to its having the same shape, above the movable platelet 17 and is therefore able to rotate solidly therewith.

25 The drawing and distribution element 18 comprises a central aperture, or discharge or outlet aperture 18a, communicating with the hole 17a and a peripheral aperture 18b communicating with the eyelet 17b.

30

Sealing elements 23, 24, 25 are provided respectively between the bottom 14 and the supporting base 22, between the bottom 14 and the fixed platelet 16 and between the movable platelet 17 and the drawing and distribution element 18.

35

The upper part of the drawing and distribution element 18 protrudes with respect to the containing body 13 and has a knurling 27 on the

40

perimeter and, at the center, a cavity 28 opening upwards.

5 The command and regulation unit 40 comprises a base 33 and a handle 45, which can be solidly associated with the latter and is hollow inside, able to contain: a drive member 41 provided with a piston 42, feeder batteries 36 and an electronic circuit 43.

10 The base 33 is provided at the center with a hole 49 on the inner wall of which there is a knurling 47 able to couple with the knurling 27 of the drawing and distribution element 18.

15 The base 33 is also provided with a central body 19, hollow on the inside, which extends in a tubular extension 19a located inside the hole 49 and protruding at the lower part with respect
20 thereto.

The tubular extension 19a is able to be inserted and clamped inside the cavity 28, putting its axial hole 19b into communication with the
25 central aperture 18a of the drawing and distribution element 18.

The central body 19 is associated at the upper part with a block 37 with which it internally
30 defines a chamber 26 inside which the membrane 20 is housed.

To be more exact, the membrane 20 is peripherally constrained between the central
35 body 19 and the block 37 and has an extension 20a on the lower part which in its normal condition, that is, when the tap 12 is closed, closes the axial hole 19b at the upper part.

40 The membrane 20 is also provided with a small through hole 32 located in correspondence with

the peripheral aperture 18b and able to make the latter communicate with the chamber 26.

The block 37 has at the center a first channel
5 29 communicating with the chamber 26 and with a second channel 31 made partly on the block 37 itself and partly on the central body 19.

The second channel 31 communicates with the
10 axial hole 19b below the membrane 20.

A plurality of supports 34 are also mounted on the block 37, which are able to support a plate 35 on which the electronic circuit 43 is
15 mounted.

The base 33 and the plate 35, together with the central body 19 and the block 37, define the seating 39 for the drive member 41 at the center
20 and, on the periphery, seatings 38 for the batteries 36.

The drive member 41, which can consist of a solenoid device or an electric motor, is fed by
25 the batteries 36 and comprises an extension 41a able to be constrained, for example screwed, to the block 37 in correspondence with the first channel 29.

30 The drive member 41 is able to move the piston 42 axially, permitting it to be selectively inserted into the first channel 29.

To be more exact, the piston 42 is able to be
35 taken from an extracted position, wherein it closes the first channel 29 and prevents it from communicating with the second channel 31, to a retracted position, wherein it leaves the first channel 29 free.

According to a variant, the piston 42 is able to close only, or also, the second channel 31.

5 The electronic circuit 43 is able to manage the drive member 41 according to what is detected by a presence sensor 44 associated therewith.

The sensor 44 is covered at the front part by an insert 46 associated with the handle 45.

10 When the device 10 is assembled, the command and regulation unit 40 is mounted above the mixer cartridge 30, and in a position outside the monoblock 11, due to the coupling between the
15 knurling 27 of the drawing and distribution element 18 and the knurling 47 of the base 33, and also between the tubular extension 19a and the cavity 28.

20 The stability of this coupling is ensured by the presence of an elastic clamping ring 48 which prevents the command and regulation unit 40 from coming off.

25 The device 10 as described heretofore functions as follows.

When there is nobody near the tap 12, the drive member 41 is inactive and has the piston 42 in
30 the extracted position, that is, closing the first channel 29.

In this condition, the chamber 26 is in communication, by means of the through hole 32,
35 with the peripheral aperture 18b only.

The water arriving from the pipes of the water system therefore rises from the peripheral aperture 18b, through the through hole 32, into
40 the chamber 26, compressing the membrane 20 which closes the axial hole 19b at the upper

part and therefore prevents the water from flowing towards the central aperture 18a and then to the delivery outlet 21.

5 When the user approaches the tap 12, the sensor 44 detects the presence and, through the electronic circuit 43, causes the activation of the drive member 41 which takes the piston 42 to the retracted position, leaving the first
10 channel 29 free which is therefore in communication with the second channel 31 and with the central aperture 18a.

In this condition the pressure inside the
15 chamber 26 is substantially atmospheric pressure, therefore the water under pressure arriving from the peripheral aperture 18b raises the extension 20a of the membrane 20 which frees the upper aperture of the axial hole 19b,
20 allowing the water to pass and flow towards the delivery outlet 21 through the central aperture 18a and the holes 17a, 16a and 14a.

When the user moves away from the tap 12, the
25 sensor 44, no longer detecting any presence, causes the de-activation of the drive member 41 which takes the piston 42 to the extracted position wherein the tap 12 is closed.

30 According to a variant, a timer is associated with the electronic circuit 43 and is able to de-activate the drive member 41 after a pre-determined time, which can be programmed as desired, from its activation.

35 The temperature of the water delivered can be regulated by making the handle 45 rotate, which, being constrained through the base 33 to the drawing and distribution element 18, causes a
40 mating movement of the latter and hence of the

movable platelet 17, thus varying the flow rates of hot and cold water to be mixed.

5 It is obvious however that modifications and/or additions can be made to the device 10 as described heretofore, but these shall remain within the field and scope of the invention.

10 For example, the mixer cartridge 30 can have different components from those shown and described here and the bottom 14 can be replaced by another, functionally equivalent element.

Claims

Art. 84
R. 43

1. Device to deliver and mix water for taps
(12), said device comprising a mixer
5 cartridge (30), able to be arranged inside
the monoblock (11) of the tap (12), means
to regulate the mixing of the water,
actuation means arranged above said
monoblock (11), able to determine the
10 opening and closing of the flow of water
and commanded electrically, an interception
element (20) able to cooperate with said
mixer cartridge (30), wherein said
actuation means comprise a movable element
15 (42) able to condition said interception
element (20) and wherein said actuation
means (42) are commanded by drive means
(41) associated with at least a presence
sensor (44), **characterized in that** at least
20 said actuation means (42), said drive means
(41) and the related battery means and
electric and electronic components (43),
said presence sensor (44) and said
interception element (20) are integrated in
25 a single unit (40), which is mounted above
said mixer cartridge (30) and associated to
it in a position outside said monoblock
(11).

R. 43(1)(a)
Prior art portion of
independent claim
wherever appropriate

R. 43(1)(b)
Characterising
portion

30 2. Device as in Claim 1, **characterized in that**
said drive means (41) comprise at least a
solenoid device.

R. 43(3), (4)
Dependent claim

35 3. Device as in Claim 1, **characterized in that**
said drive means (41) comprise at least an
electric motor.

40 4. Device as in Claim 1, **characterized in that**
said drive means (41) are fed by battery
means comprising batteries (36).

5. Device as in Claim 1, **characterized in that** timer means are associated with said drive means (41) in order to automatically deactivate said drive means (41) after a pre-determined time from when said sensor (44) detects the presence of a user.
6. Device as in Claim 5, **characterized in that** said timer means are selectively programmable.
7. Device as in Claim 4, **characterized in that** said unit (40) comprises housing seatings (38) for said batteries (36).
8. Device as in Claim 1, **characterized in that** said unit (40) integrally comprises said means to regulate the mixing.
9. Device as in Claim 8, **characterized in that** said regulation means comprise a handle (45) able to cooperate with the mixing means of said mixer cartridge (30).
10. Device as in Claim 9, **characterized in that** the function of said handle (45) is to cover and protect the components of said unit (40).
11. Device as in Claim 1, **characterized in that** said mixer cartridge (30) comprises water distribution means (18) protruding from said monoblock (11) on which said unit (40) can be coupled.
12. Device as in Claim 11, **characterized in that** said unit (40) and said mixer cartridge (30) cooperate with reciprocal clamping means (48).

13. Device as in Claim 1, **characterized in that** said movable element (42) is able to assume at least a first position wherein it defines the closing and a second position wherein it defines the opening of said tap (12).
14. Device as in Claim 13, **characterized in that** said movable element consists of a piston (42) able to assume an extracted position wherein the tap (12) is closed and a retracted position wherein the tap (12) is open.
15. Device as in Claim 14, **characterized in that** said interception element consists of a membrane (20) housed in a chamber (26) located in communication with said mixer cartridge (30), said membrane (20) being able to assume a first position wherein it does not allow the water to be delivered from the tap (12), defined by the extracted position of said piston (42), and a second position wherein it allows said delivery, defined by the retracted position of said piston (42).
16. Device as in Claims 11, 14 and 15, **characterized in that** said chamber (26) communicates with the outside by means of at least a channel (29, 31) able to be selectively closed by said piston (42), and cooperates with said distribution means (18), said channel (29, 31) being closed in the extracted position of said piston (42), and allowing said chamber (26) to be filled with water so as to maintain said membrane (20) in said first position, and being open in the retracted position of said piston (42) to allow said membrane (20) to be arranged in said second position.

17. Device as in Claim 16, **characterized in**
that said chamber (26) communicates with
the outside by means of two inter-connected
channels (29, 31), at least one (29 or 31)
5 of said channels being able to be
selectively closed by said piston (42).

18. Device as in Claim 16 or 17, **characterized**
in that said membrane (20) is arranged
10 lowered in its said first position and is
able to be raised at least partly in its
said second position due to the effect of
the pressure of the water passing in said
distribution means (18).

15
19. Device as in Claim 16, **characterized in**
that said membrane (20) is provided with a
through hole (32), cooperating with said
distribution means (18), and able to allow
20 said chamber (26) to be filled with water.

Abstract

Art. 85

Device to deliver and mix water

R. 47(1)
Title of invention

Device (10) to deliver and mix water for taps (12), said device comprising a mixer cartridge (30), able to be arranged inside the monoblock (11) of the tap (12), means to regulate the mixing of the water and actuation means arranged above said monoblock (11), able to determine the opening and closing of the flow of water, said actuation means being commanded electrically and comprising an interception element (20) able to cooperate with said mixer cartridge (30).

R. 47(2), (3), (5)
Content of abstract

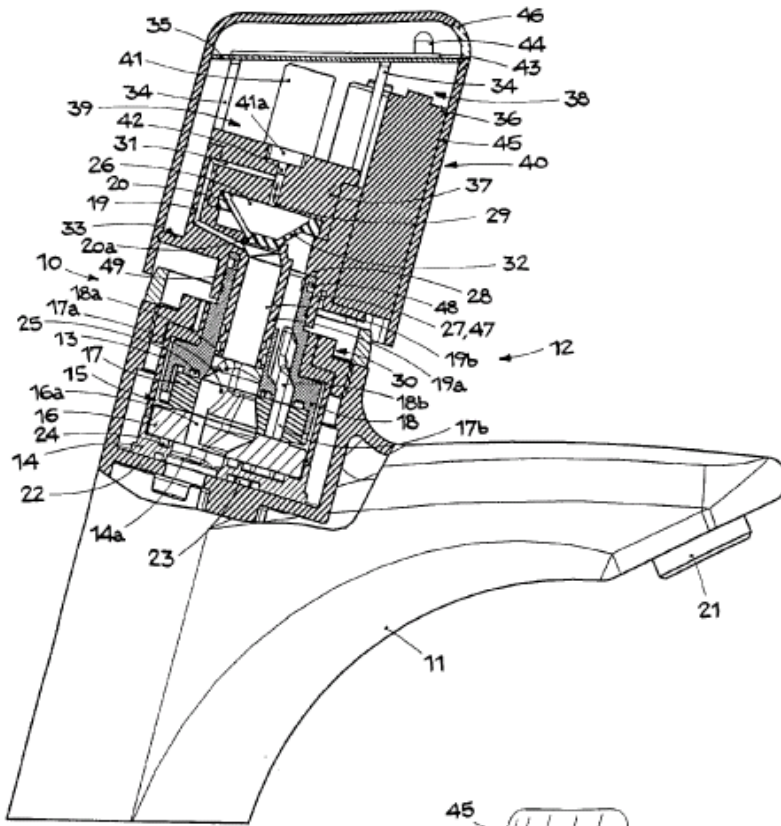

Fig. 1

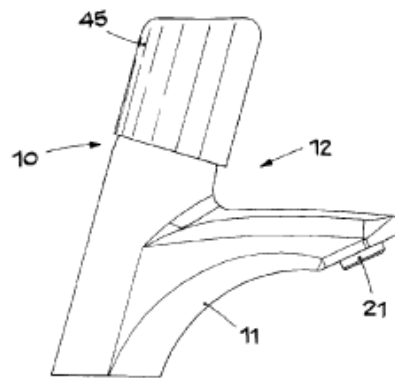

Fig. 2

Annex IV

Authorities with which European patent applications may be filed

I. European Patent Office

(a) Munich headquarters

European Patent Office
Erhardtstrasse 27
80469 Munich
Germany
Postal address:
European Patent Office
80298 Munich
Germany
Tel.: +49 (0)89 2399-0
Fax: +49 (0)89 2399-4465

(b) The Hague

European Patent Office
Branch at The Hague
Patentlaan 2
2288 EE Rijswijk
Netherlands
Postal address:
European Patent Office
Postfach 5818
2280 HV Rijswijk
Netherlands
Tel.: +31 (0)70 340-2040
Fax: +31 (0)70 340-3016

(c) Berlin

European Patent Office
Gitschiner Strasse 103
10969 Berlin
Germany
Postal address:
European Patent Office
10958 Berlin
Germany.
Tel.: +49 (0)30 25901-0
Fax: +49 (0)30 25901-840

II. National authorities

For a summary of the contracting states' chief national provisions governing compulsory and optional filing of patent applications with central industrial property offices and other competent authorities, see Table II in "**National law relating to the EPC**" (see point 4). This table also contains the addresses of the central industrial property offices.

Note: European divisional applications must always be filed with the EPO (see point 208 ff).

Annex V

The requirements of the contracting states regarding translations of European patent specifications

I. Article 65 EPC

Under Article 65(1) EPC, any contracting state may prescribe that if the text in which the European Patent Office intends to grant a European patent or limit or maintain a European patent as amended for that state is not drawn up in one of its official languages, the applicant for or proprietor of the patent must supply its central industrial property office with a translation of this text in one of its official languages at his option or, where that state has prescribed the use of one specific official language, in that language.

II. Requirements of the contracting states

The legal position in the contracting states is given in "**National law relating to the EPC**", Table IV (see point 4).

Note: all those states which require a translation of the European patent specification have prescribed that, in the event of failure to observe the relevant national provisions, the European patent will be deemed to be void ab initio.

Annex VI

Time limits

Charts showing time limits to be met by applicants

The EPC provides for three types of time limit:

1. Time limits computed from the actual or deemed date of filing or the date of priority
2. Time limits of a duration laid down in the EPC which are computed from an event other than the date of filing or priority
3. Time limits laid down by the EPO in the course of the grant procedure

The EPO reminds applicants of all time limits of types 2 and 3 above, apart from those for further processing (see point 225) and re-establishment of rights (see points 226-227).

The charts below are particularly designed to help applicants keep track of time limits of type 1.

Chart A relates to a European patent application which is a first filing.

Chart B relates to a European patent application which claims the priority of an earlier application and is assumed to have been filed ten months after the earlier application.

The charts do not take into account the special time limits which apply to European divisional applications and new European patent applications filed in accordance with Article 61(1)(b) (see Rules 15(2), 36(2), 51(3) and (6) and 60(2)).

Chart A Important time limits laid down in the EPC where **no priority** is claimed in the European patent application*

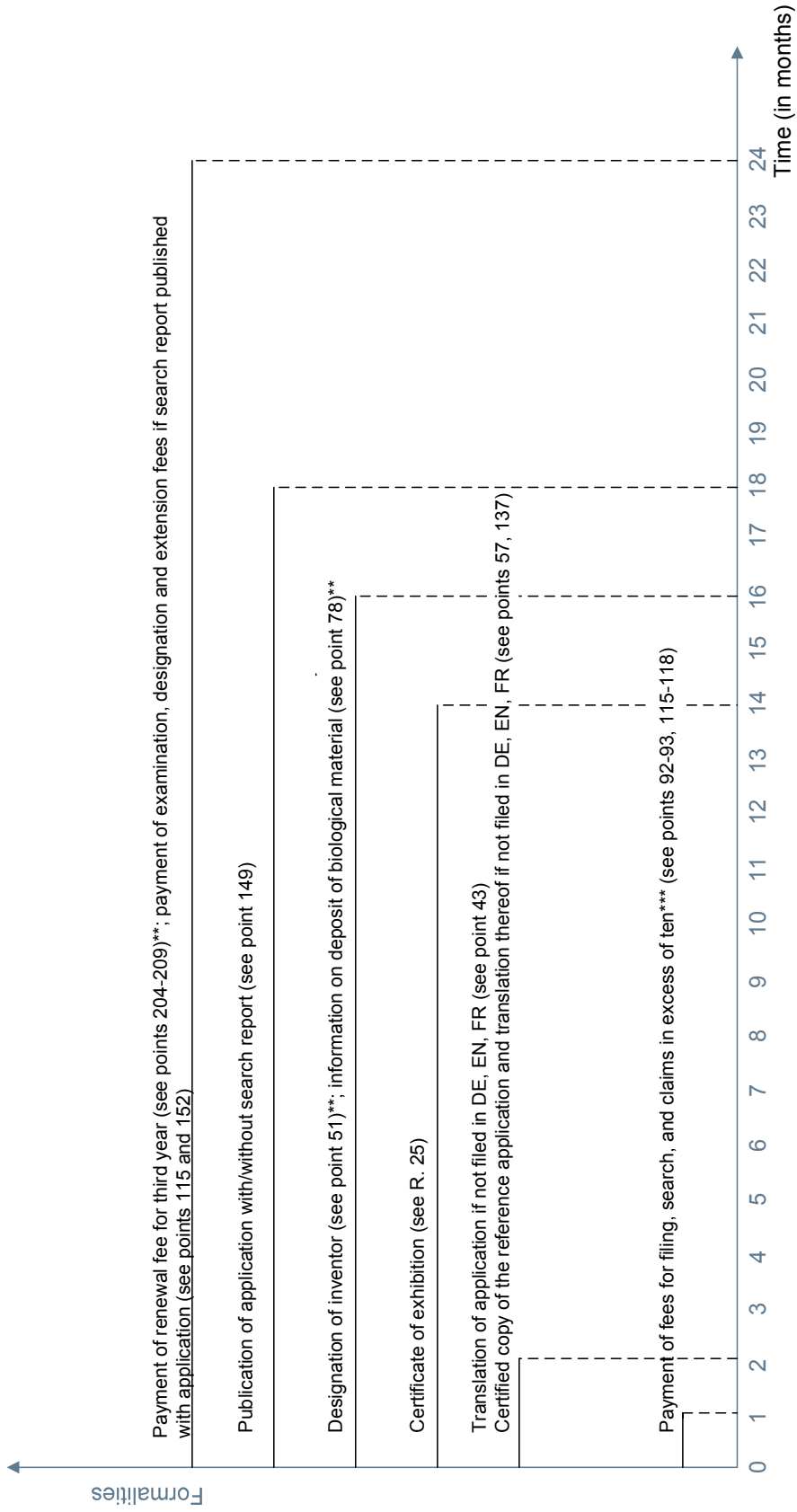

0 Filing of European patent application

* But see R. 131 and 57(1)

** Time limit computed from date of filing, possibly later than date on which application was actually received (see Art. 80, R. 55 and 56)

*** If claims filed with application

Chart B Important time limits laid down in the EPC where **priority is claimed** in the European patent application*

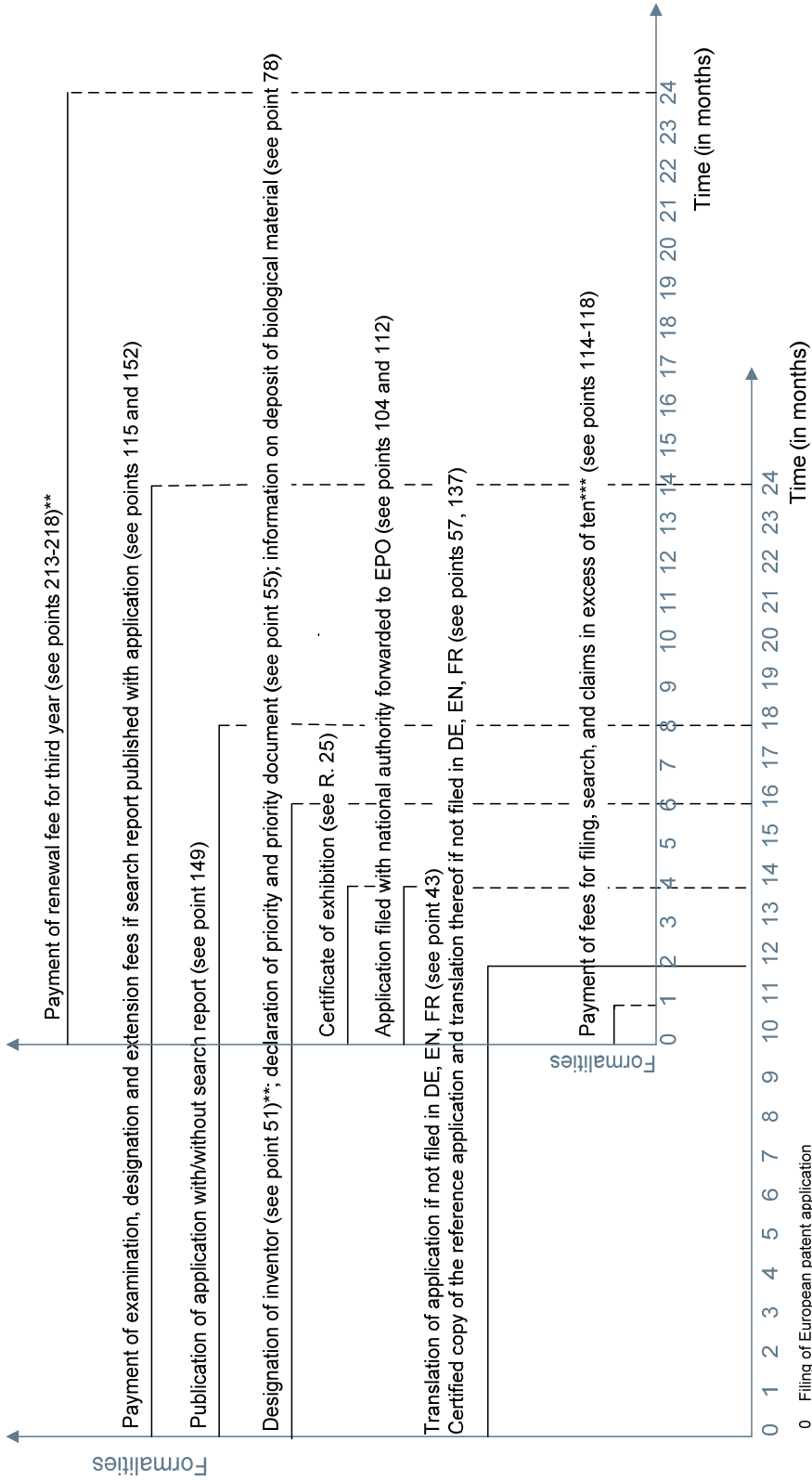

0 Filing of European patent application
 0 Filing of earlier application
 * But see R. 131 and 57(1)
 ** Time limit computed from date of filing, possibly later than date on which application was actually received (see Art. 80, R. 55 and 56)
 *** If claims filed with application

Annex VII

Fees

I. Fees provided for in the EPC

The guidance for the payment of fees published periodically in the Official Journal enables you to find out at any time which rules relating to fees are currently applicable and whether any information given in this Guide has changed since it was published. You are advised to check the current fee amounts in the schedule of fees, costs and prices, which is available on the EPO website and from the EPO's Information Offices.

II. Form for the payment of fees and costs

The form for the payment of fees and costs (Form 1010) can be downloaded from the EPO website (www.epo.org).

III. Further information on fees

Further information on fees, such as the schedule of fees, costs and prices of the EPO and the list of bank accounts of the European Patent Organisation, is published on the EPO website at www.epo.org.

Annex VIII

Patent information services

File inspection and communication of information from files

1. The files relating to published European patent applications and patents are available for online inspection. Access to online file inspection is provided via the EPO website (www.epo.org) under "Register Plus".

Art. 128(4)
R. 145
Guid. A-XII
OJ 2000, 474
OJ 2003, 370, 373

On request, copies of the files can be made available for inspection. This is subject to payment of a fee.

European Patent Register and European Patent Bulletin

2. The EPO offers Internet access to the Online European Patent Register. Users of the European patent system can go to www.epo.org to look up procedural data on European patents and patent applications.

Art. 127
R. 143
OJ 2001, 249
OJ 2003, 23, 69

The Online Register provides bibliographic data together with procedural data from the date of publication to the grant of the patent, plus any data concerning opposition and appeal proceedings.

Internet access to the Online Register is free of charge.

3. The data in the European Patent Register is published weekly in the European Patent Bulletin, where the bibliographic data relating to published European patent applications and granted European patents is arranged according to a number of reference criteria, including

Art. 129(a)

- the International Patent Classification,
- European publication numbers,
- names of applicants/proprietors.

The European Patent Bulletin is available online at www.epo.org.

Patent documents

4. The EPO also publishes:
 - European patent applications (A documents) on CD-ROM and online
 - European patent specifications (B documents) on CD-ROM and online

Art. 93
OJ 1990, 81
Art. 98, 103

Published documents are available online via the publication server at <http://www.epo.org/patents/patent-information/european-patent-documents/publication-server.html>

Information on other EPO CD-ROM products can be downloaded from the EPO website at www.epo.org/patents/patent-information/subscription.html

Official Journal, and Guidelines for Examination

5. The EPO's other standard publications include
- the Official Journal (OJ), containing in particular the legislative acts of the Organisation's Administrative Council, the decisions and notices of the President of the EPO, information about fees and costs, and selected decisions of the boards of appeal, and
 - the Guidelines for Examination in the European Patent Office.

Art. 129(b)
Art. 10(2)(a)

These publications are also available online on the EPO's website (www.epo.org).

Terms and conditions

6. The EPO's sub-office in Vienna is responsible for all patent information services (document dispatch, online access, etc.).

Vienna sub-office
Postfach 90
1031 Vienna
Austria
Tel.: +43 (0)1 521 26 0
Fax: +43 (0)1 521 26 3591
e-mail: infowien@epo.org

Contact

Further information about the European Patent Office and the procedures involved in applying for a European patent is available from the EPO's Information Offices. You can contact EPO Customer Services as follows:

Tel.: +49 (0)89 2399-4636
info@epo.org

Munich
Information Office
Grasserstr. 6
80339 Munich
Germany

The Hague
Information Office
Patentlaan 2
2288 EE Rijswijk
Netherlands

To order copies of this guide, contact us on bookorder@epo.org

Imprint

Edited and published by

European Patent Office

Munich

Germany

© EPO 2007

Responsible for the content

Directorate 5.2.1

Printed by

Mediengruppe Universal, Munich

Printed in Germany